

VERMEIREN

D200

INSTRUCTION MANUAL





Instructions to the specialist dealer

This instruction manual is part and parcel of the product and must accompany every product sold.

Version: E, 2014-08

All rights reserved, including translation.

No part of this manual may be reproduced in any form whatsoever (print, photocopy, microfilm or any other process) without written permission of the publisher, or processed, duplicated or distributed by using electronic systems.

© N.V. Vermeiren N.V. 2014



Contents

Preface	2
1 Product description	3
1.1 Intended Use.....	3
1.2 Technical specifications	4
1.3 Drawing.....	5
1.4 Accessories.....	5
1.5 Location identification plate.....	6
1.6 Explanation of symbols	6
1.7 Safety rules	6
2 Use	7
2.1 Carrying the wheelchair	7
2.2 Mounting the rear wheels	7
2.3 Unfolding the wheelchair	7
2.4 Mounting or removing of the footrest	8
2.5 Operating the brakes.....	8
2.6 Mounting or removing of armrests.....	8
2.7 Transfer in and out the wheelchair	10
2.8 Correct position in the wheelchair	10
2.9 Riding the wheelchair.....	10
2.10 Moving on slopes	11
2.11 Negotiating steps or curbs	11
2.12 Fold up the wheelchair	13
2.13 Taking off the wheels	13
2.14 Transport in the car.....	13
2.15 Use of the wheelchair as seat in a motor vehicle	13
3 Installation and adjustment	16
3.1 Tools	16
3.2 Manner of delivery	16
3.3 Adjusting the seat height	16
3.4 Adjust the brakes	17
3.5 Adjusting of the footrest.....	18
3.6 Adjusting the armpad	19
4 Maintenance	19



Preface

First of all we want to thank you for putting your trust in us by selecting one of our wheelchairs.

The Vermeiren wheelchairs are the result of many years of research and experience. During the development, special attention was given to the ease of use and the serviceability of the wheelchair.

The expected lifetime of 8 years for your wheelchair is strongly influenced by the care and maintenance of the wheelchair.

This manual will help you get acquainted with the operation of your wheelchair.

Following the user instructions and the maintenance instructions are an essential part of the warranty.

This manual reflects the latest product developments. Vermeiren has the right to introduce changes without the obligation to adapt or replace previously delivered models.

For any further questions, please consult your specialist dealer.

1 Product description

1.1 *Intended Use*

The wheelchair is intended for people with walking difficulties or no walking abilities.

The wheelchair is designed to transport 1 person.

The wheelchair is suited for indoor and outdoor use.

The user can propel the wheelchair by himself or have the wheelchair pushed by an attendant.

The different types of fittings and accessories, and the modular construction allow full use by persons disabled by:

- paralysis
- loss of limbs (leg amputation)
- limb defects or deformations
- stiff or damaged joints
- heart insufficiencies and poor blood circulation
- balance disturbances
- cachexia (decrease in muscle)
- and also for aged persons.

When providing for individual requirements:

- body size and weight (max. 130 kg)
- physical and psychological condition
- residential circumstances
- environment

should be taken into consideration.

Your wheelchair should only be used on surfaces where all four wheels are touching the ground and where there is sufficient contact to propel the wheels equally.

You should practice for use on uneven surfaces (cobblestones, etc.), slopes, curves and to get past obstacles (curbs, etc.).

The wheelchair should not be used as a ladder, nor is it a transport for heavy or hot objects.

When used on mats, carpeted floors or loose floor coverings, the floor covering can get damaged.

Use only Vermeiren approved accessories.

The manufacturer is not liable for damage caused by the lack of or improper service or as a result of not following instructions from this manual.

Compliance with the user and maintenance instructions are an essential part of the guarantee conditions.

1.2 Technical specifications

Technical terms below are valid for the wheelchair in standard settings.

If other footrest / armrest or other accessories are used, the tabulated values will change.

Make	Vermeiren							
Address	Vermeirenplein 1/15, B-2920 Kalmthout							
Type	Manual wheelchair							
Model	D200							
Maximum occupant mass	130 kg							
Description	Dimensions							
Effective seat width	380 mm	400 mm	420 mm	440 mm	460 mm	480 mm	500 mm	520 mm
Overall width (depends on the seat width)	580 mm	600 mm	620 mm	640 mm	660 mm	680 mm	700 mm	720 mm
Description	Dimensions Min.				Dimensions Max.			
Overall length with footrest	1010 mm							
Folded length	1010 mm							
Folded width	300 mm							
Folded height	880 mm				940 mm			
Total mass	16,8 kg							
Mass of heaviest part	9,3 kg							
Static stability downhill	16° (in standard configuration)							
Static stability uphill	12° (in standard configuration)							
Static stability sideways	20° (in standard configuration)							
Maximum safe slope	12°							
Obstacle climbing	60 mm							
Seat plane angle	5°							
Effective seat depth	430 mm							
Seat surface height at front edge	470 mm				530 mm			
Backrest angle	5°							
Backrest height	420 mm							
Distance between footrest and seat	410 mm							
Angle between seat and footplate	-1,5°				18,5°			
Angle between leg footrest and footplate	80°				100°			
Angle between seat and leg footrest	98,5°							
Distance between armpad and seat	220 mm				240 mm			
Front location of armrest structure	410 mm							
Handrim diameter	535 mm							
Horizontal location of axle (deflection)	37 mm							
Minimum turning radius	1500 mm							
Diameter PU Rear wheels	22"				24"			
Diameter PU steering wheels	200 mm							
Storage and use temperature	+ 5 °C				+ 41 °C			
Storage and use humidity	30%				70%			
We reserve the right to introduce technical changes. Measurement tolerance ± 15 mm / 1,5 kg / °								

Table 1: Technical specifications

The wheelchair complies to the requirements set up in:

ISO 7176-8: Requirements and test methods for static, impact and fatigue strengths.

ISO 7176-16: Resistance to ignition of upholstered parts

1.3 Drawing

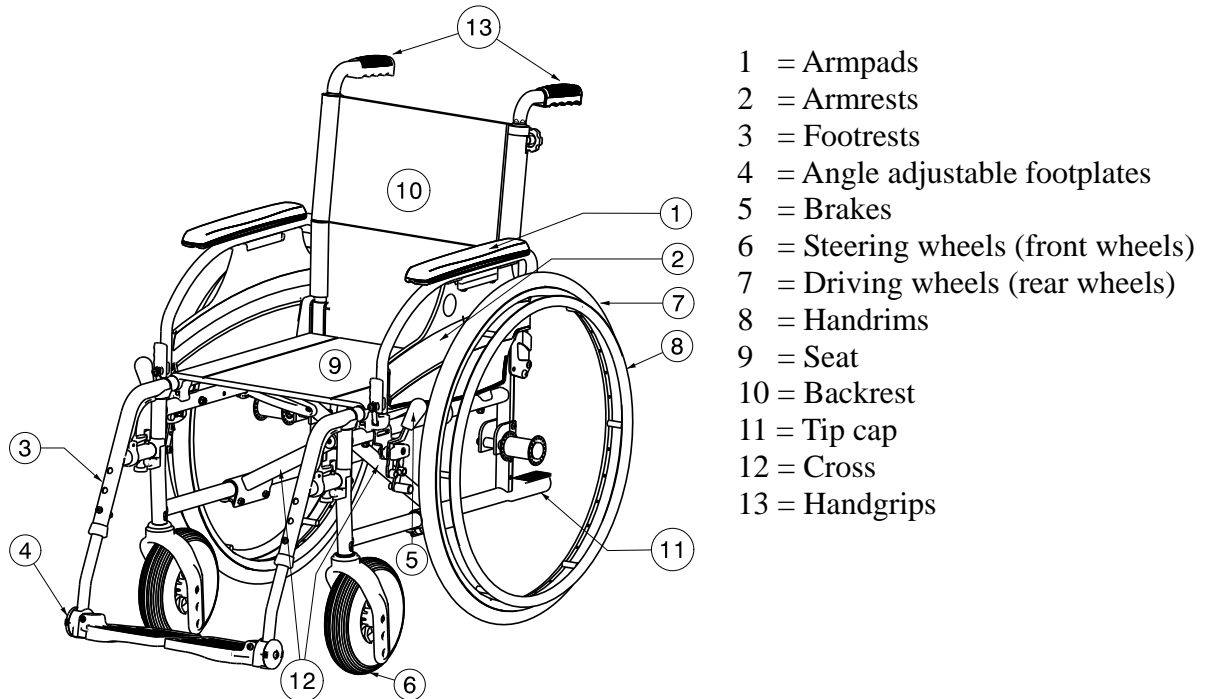

1.4 Accessories

The following accessories are available for the D200:

- Anterior pelvic belt (B20) for mounting on the tubes of the back (see according manual)
- Anti-tipping device (B78) for mounting on the bottom frame (see according manual)

1.5 Location identification plate

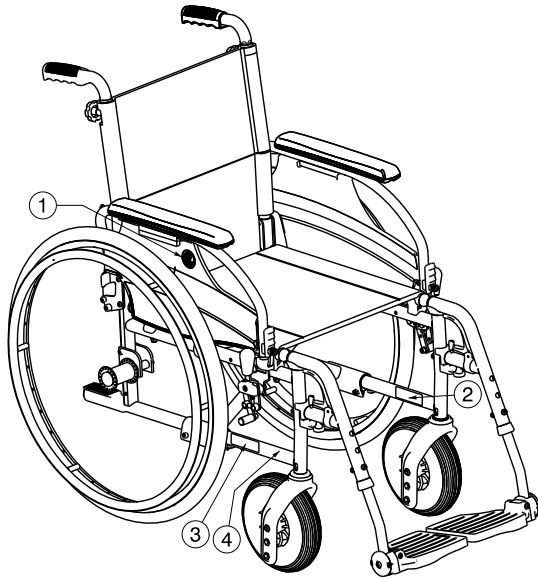

- 1 = Logo Vermeiren
- 2 = Identification plate
- 3 = Name Vermeiren
- 4 = Crash tested

1.6 Explanation of symbols



Maximum mass



Indoor and outdoor use



Maximum Safe Slope



CE conformity



Type designation

1.7 Safety rules

- ⚠ To prevent injury and/or damage to your wheelchair, make sure that no objects and/or body parts are caught in the spokes of the driving wheels.
- ⚠ The parking brakes should be applied before getting into and out of the wheelchair.
- ⚠ When getting into and out of the wheelchair, do not stand on the footplates. These should be folded up beforehand, or the footrest should be swung completely outwards out of the way.
- ⚠ Investigate the effects of shifting the centre of gravity on the behavior of the wheelchair, for example on up or down gradients, on laterally sloping ground, or when overcoming obstacles. Obtain support from an attendant.
- ⚠ If you want to pick up something (lying in front of, on the side, or to the rear of the wheelchair), you should not lean too far out to avoid tipping over.
- ⚠ When moving through doors, arches, etc. ensure that there is enough room at the sides so that you do not get your hands or arms caught or crushed and that there is no damage to the wheelchair.
- ⚠ Only use your wheelchair according to regulations. For example, avoid uncontrolled rolling against obstacles (steps, curbs, doorframes, etc) or dropping down from ledges. The manufacturer cannot assume liability for damage caused by overloading, collision or other improper use.

- ⚠ Stairs may only be negotiated when aided by another person. If furnishings like drive-on, ramps or lifts are available, use them.
- ⚠ When moving on the public highway, you are subject to the rules of the road.
- ⚠ When driving your wheelchair, you should not be under the influence of alcohol or medicine as in the case of driving other vehicles. This also applies to indoor driving.
- ⚠ When travelling outdoors, adapt your driving to weather and traffic conditions.
- ⚠ To be better visible when driving in the dark, wear the brightest possible clothing or clothes with reflectors, and check that the reflectors mounted on the sides and rear of the wheelchair are clearly visible.
- ⚠ Never exceed the maximum load of 130 kg.

2 Use

This chapter describes the everyday use. **These instructions are for the user and the specialist dealer.**

The wheelchair is delivered fully assembled by your specialist dealer. The instructions intended for the specialist dealer on how to set up the wheelchair are given in § 3.

2.1 Carrying the wheelchair

The best way to carry the wheelchair is to make use of the wheels and roll the wheelchair.

If this is not possible (e.g. when the rear wheels are taken off for transportation in a car), firmly grasp the frame on the front and the grips. Do not use the foot or arm rests or the wheels to grasp the wheelchair.

2.2 Mounting the rear wheels

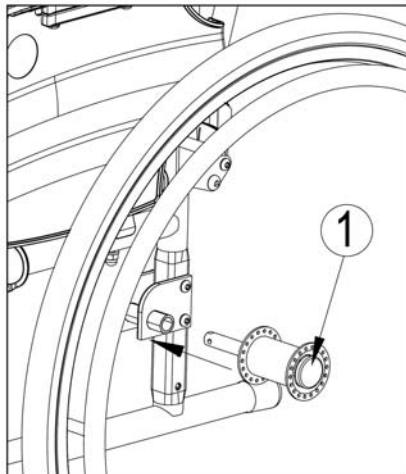

1. Take the rear wheel and push on button ①.
2. Keep the button pushed in and mount the rear wheels axle till it stops.
3. Release the button ①.
4. Check that the wheels are secured.

2.3 Unfolding the wheelchair

⚠ **CAUTION: Risk of clamping – Keep fingers away from moving parts of the wheelchair.**

1. Position yourself behind the wheelchair.
2. Use the hand-grips to open the wheelchair as much as possible.
3. Position yourself at the front of the wheelchair.
4. Push both seating tubes down till they are fixed in their position.

2.4 Mounting or removing of the footrest

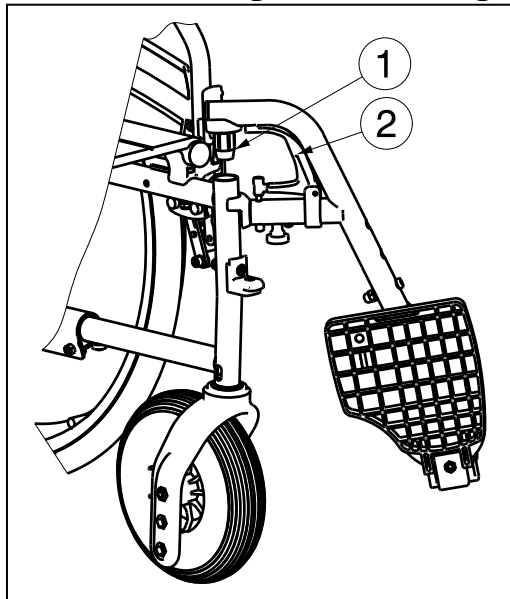

The mounting of the footrest is done as follows:

1. Hold the footrest sideways at the outside of the wheelchair frame and mount the tube hood ① into the frame.
2. Swing the footrest inwards till it clicks in position.
3. Swing the foot plate downwards.

To take off the footrests:

1. Pull handle ②.
2. Swing the footrest to the outside of the wheelchair till it comes loose from the guidance.
3. Pull the footrest from tube hood ①.

2.5 Operating the brakes

- ⚠ **WARNING:** The brakes are not used to slow down the wheelchair during movements – Use the brake only to prevent the wheelchair from unintended movements.
- ⚠ **WARNING:** Good operation of the brakes is influenced by wear and contamination of the tires (water, oil, mud, ...) – Check the condition of the tires before each use.
- ⚠ **WARNING:** The brakes are adjustable and can wear – Check the operation of the brakes before each use.
- ⚠ **WARNING:** Risk of clamping - Do not touch the wheelchair frame with your hands, fingers when applying, releasing the brakes.

To apply the brakes:

1. Push the brake handles forward till you feel a distinctive click.

- ⚠ **CAUTION:** Risk of unintended movement – Make sure the wheelchair is on a flat horizontal surface before releasing the brakes. Never release both brakes simultaneously.

To release the brakes:

1. Release one brake by pulling the handle backwards.
2. Hold the hand-rim of the released wheel with your hand.
3. Release the second brake by pulling the handle backwards.

2.6 Mounting or removing of armrests

The arm supports of the wheelchair can be mounted by following instructions.

- ⚠ **CAUTION:** Risk of clamping – Keep fingers, buckles and clothes away from the bottom side of the armrest.
- ⚠ **CAUTION:** Risk of clamping – Be careful that your fingers, hands are not squeezed between the rear wheels and the side plate of the armrests.

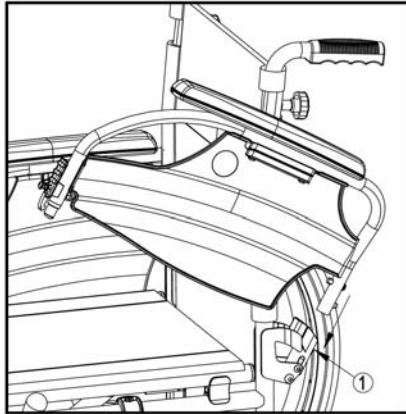

1. Mount the rear tube of the armrest in tube hood ①.
2. Make sure the armrest clicks in the locking mechanism.
3. Fold the armrest forward.

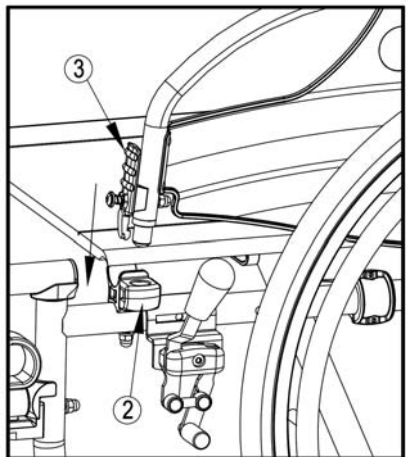

4. Click the front tube of the armrest in tube hood ②.

To open and remove the armrest:

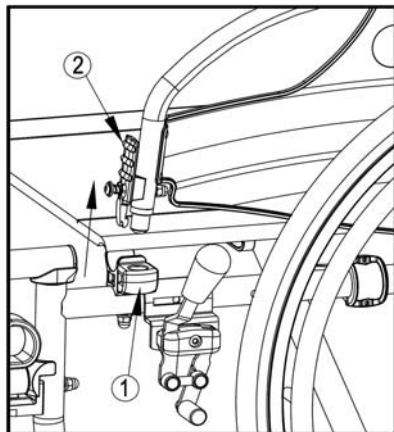

1. Press lever ② and pull the front of the armrest upwards.
2. Fold the armrest backwards.

3. To remove the armrest, press button ③ and pull the rear of the armrest from tube hood ④.

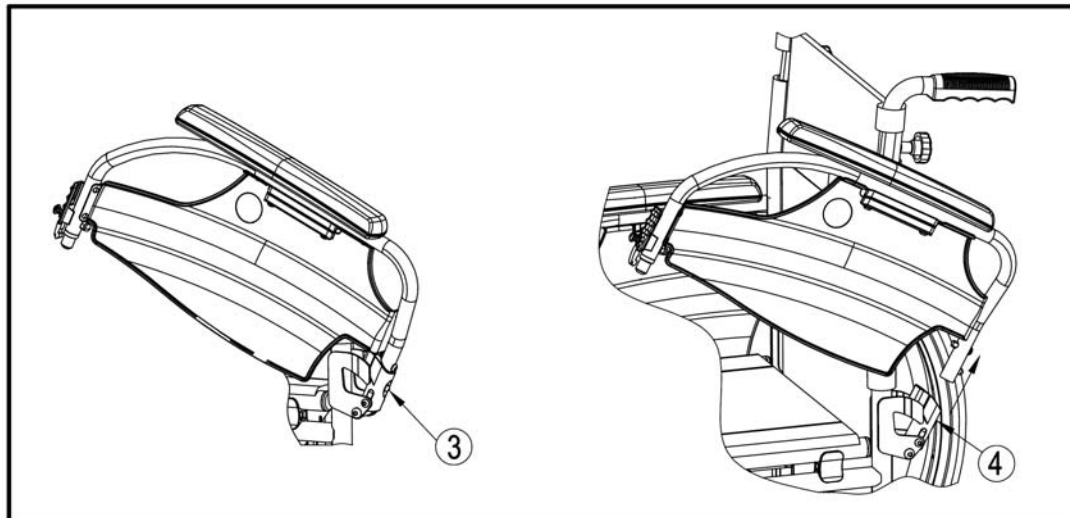

2.7 Transfer in and out the wheelchair

- ⚠ **CAUTION:** In case you cannot perform the transfer in a safe manner, ask someone to assist you.
- ⚠ **CAUTION:** Risk of tipping over of the wheelchair – Do not stand on the footplate.

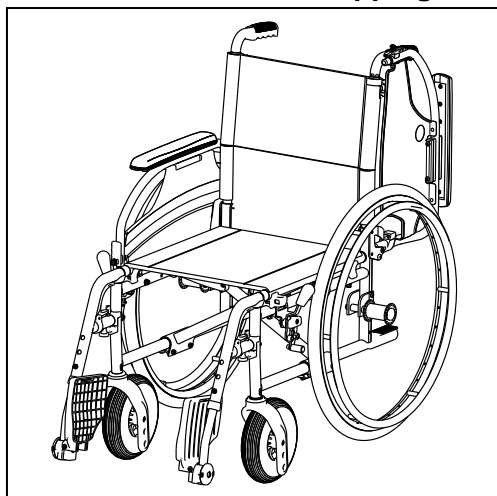

1. Position the wheelchair as close as possible to the chair, couch or bed to/from you wish to transfer.
2. Check both brakes from the wheelchair are in the on position.
3. Fold the footplates upwards to prevent standing on them.
4. If the transfer is on the side of the wheelchair, fold the armrest on that side upwards (see § 2.6).
5. Transfer to/from the wheelchair.

2.8 Correct position in the wheelchair

Some recommendations for a comfortable use of the wheelchair:

- Position your backside as close as possible to the back rest.
- Make sure your upper legs are horizontal – If needed adjust the length of the footrests (see § 3.5.1).

2.9 Riding the wheelchair

- ⚠ **WARNING:** Risk of clamping – Prevent your fingers from being caught by the wheels spokes.
- ⚠ **WARNING:** Risk of clamping – Prevent that your fingers, hands are clamped between the hand rim and rear wheel.
- ⚠ **WARNING:** Risk of clamping – Be careful passing through restricted passages (e.g. doors).
- ⚠ **WARNING:** Risk of burns – Be careful when driving in hot or cold environments (sunshine, extreme cold, saunas, etc.) for a sufficient amount of time and when touching - Surfaces can assume the environment temperatures.

1. Release the brakes.
2. Take both hand rims at their highest position.
3. Lean forward and push the hand rims forward until straight arms.
4. Swing your arms loosely back to the hand rims topside and repeat the movement.

2.10 Moving on slopes

- ⚠ **WARNING: Control your speed – Moving on slopes as slow as possible.**
- ⚠ **WARNING: Consider the capacities of your attendant – If your attendant does not have enough force to control the wheelchair, put on the brakes.**
- ⚠ **WARNING: Risk of tipping over – Lean forward to move your centre of gravity forward. To improve a better stability.**



1. If available on the wheelchair, wear the safety belt.
2. Do not attempt moving on too high slopes. The maximum slope angles (upwards and downwards) are mentioned in table 1.
3. Ask an attendant to help you moving on the slope.
4. Lean forward to move your centre of gravity forward.

2.11 Negotiating steps or curbs

2.11.1 Getting down steps or curbs

Riding down low curbs can be done moving forwards. Make sure that the footplates do not touch the ground.



A practiced user can negotiate small steps or curbs by himself:

- ⚠ **WARNING: Risk of tipping over – If you do not have enough experience with your wheelchair, ask assistance of an attendant.**
1. Bring balance on the rear wheels to reduce the pressure on the front wheels.
 2. Negotiate the curbs.

Higher curbs can be taken forward with an attendant:

1. Ask the attendant to tip the wheelchair slightly backwards.
2. Get past the curbs while moving on the rear wheels.
3. Put the wheelchair back on the four wheels.



An experienced user can negotiate higher curbs by himself. This is best done backwards.

1. Turn the wheelchair to have the rear wheels facing the curb.
2. Lean forward to move your centre of gravity forward.
3. Move the wheelchair close to the curbs.
4. Use the hand rim to roll-off wheelchair from the curb in a controlled manner.

2.11.2 Moving up steps or curbs

Moving up steps or curbs with attendant as follows:



1. Prevent the footplates from touching the curb.
2. Ask the attendant to tip the wheelchair backwards, just enough to move the front wheels over the curb.
3. Lean backwards to move your centre of gravity above the rear wheel.
4. Place the front wheels on the curb.
5. Roll rear wheels of the wheelchair over the curb.

Higher curbs are negotiated backwards:

1. Turn the wheelchair to have the rear wheels facing the curb.
2. Lean backwards and move your centre of gravity above the rear wheels.
3. Ask the attendant to pull the wheelchair on the curb.
4. Take back the normal position in the wheelchair.

An experienced user can negotiate curbs by himself:

⚠ WARNING: Risk of tipping over – If you have not enough experience to control the wheelchair, get help from an attendant.



1. Drive until the curbs.
2. Ensure that the footrest do not touch the curbs.
3. Lean backwards so you are balancing on the rear wheels.



4. Role the front wheels balancing over the curbs.
5. Bend forwards for more stability.
6. Role the rear wheels over the curbs.

2.11.3 Taking of stairs

Taking of stairs while you staying in the wheelchair shall be according following rules:

⚠ WARNING: Risk of tipping over – Taking of stairs shall always with 2 attendants.

1. Remove the footrests.
2. One attendant tip the wheelchair slightly backwards.
3. The second attendant take the front of the frame.
4. Stay calm, avoid sudden movements and keep your arms inside the wheelchair.
5. Take the steps on the rear wheels of the wheelchair.
6. Mounting the footrests back after taking the stair.

2.12 Fold up the wheelchair

⚠ CAUTION: Chance of pinching – Do not place fingers between the components of the wheelchair.

1. Fold or remove the footplates (see § 2.4).
2. Take the seat on the front side and backside and pull it up.

2.13 Taking off the wheels

To facilitate the transport off the wheelchair the rear wheels can be taken off:

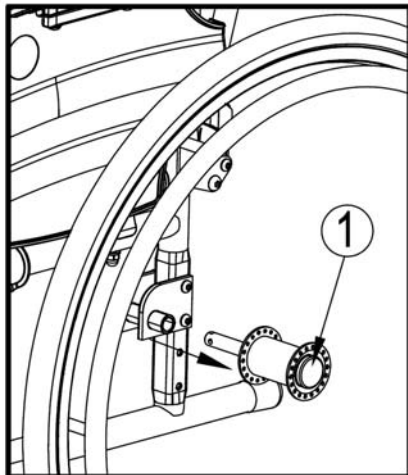

1. Make sure the brakes standing in the off position.
2. Take the wheelchair to the side frame where you want to remove the wheel.
3. Press the button ① in the center of the wheel hub.
4. Pull the wheel away from the frame.

2.14 Transport in the car

⚠ WARNING: Risk of injury – See that the wheelchair is attached properly. So you can avoid injury from the passengers during collision or sudden braking.

⚠ WARNING: Risk of injury – Use for attaching the wheelchair and passenger NEVER the same seatbelt.

To transport the wheelchair in the car use following steps:

1. Remove footrests and accessories.
2. Store footrests and accessories safely.
3. If possible, fold the wheelchair and remove the wheels.
4. Place the wheelchair in the luggage place.
5. If the wheelchair and the passenger compartment is NOT separated, attach the frame of the wheelchair securely to the vehicle. You can use the available safety belts in the vehicle.

2.15 Use of the wheelchair as seat in a motor vehicle

⚠ WARNING: Risk of injury - The wheelchair may only be used as a seat in a motor vehicle when the handgrips are placed in the lowest position. In other cases it is forbidden to use the wheelchair as a seat in a motor vehicle.

⚠ WARNING: The wheelchair has passed the crash of ISO 7176-19: 2008 and, as such, has been designed and tested for use only as forward-facing seat in a motor vehicle.

⚠ WARNING: The wheelchair's pelvic belt alone is not suited as an occupant restraint belt.

The wheelchair is tested using the four-point strap-tie system and a 3-point occupant-restraint system.

Whenever feasible, use the seat of the vehicle and store the wheelchair in the cargo area.

Steps to secure the wheelchair in a motor vehicle:

1. Check that the vehicle is equipped with a suitable wheelchair tie down and occupant-restraint system, conform ISO 10542.
2. Check that the components of the wheelchair tie down and occupant restraint system are not frayed, contaminated, damaged or broken.
3. If equipped with an adjustable seat and/or back tilt, make sure that the wheelchair user is sitting as upright as possible. If the user's condition prevents this, a risk assessment should be done to evaluate the user's safety during transit.
4. Remove all mounted accessories such as trays and respiratory equipment, and secure them in a safe place.
5. Position the wheelchair facing forward in the travelling direction, centrally between the tie-down rails mounted in the floor of the vehicle.
6. Make sure that the indicated zones around the wheelchair user are clear from rigid vehicle parts.

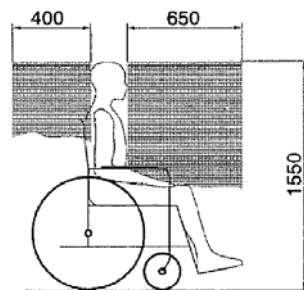

figure 1

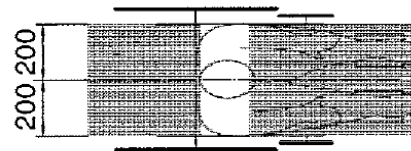

figure 2

7. Mount the front securement straps according to the instructions of the strap-system manufacturer at the indicated place. (figure 3)
This place is marked on the wheelchair with a symbol. (figure 4)
8. Roll back the wheelchair until the front straps are tight.
9. Apply the wheelchair brake.
10. Mount the back securement straps according to the instructions of the strap-system manufacturer at the indicated place. (figure 3)
11. This place is marked on the wheelchair with a symbol. (figure 4)

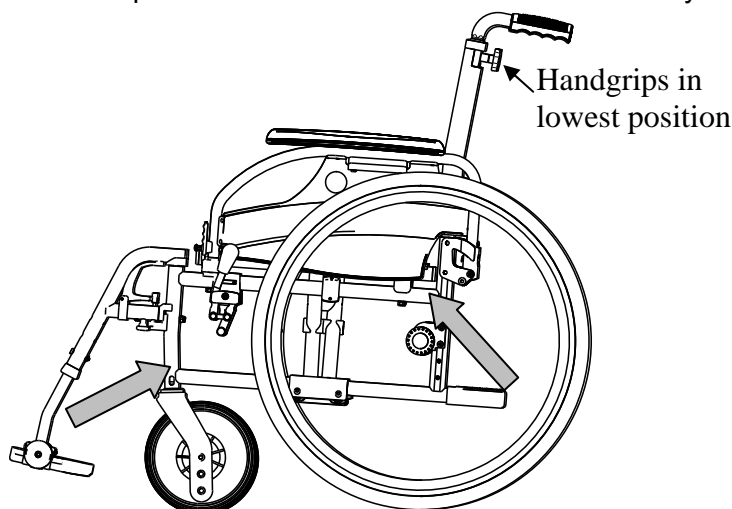

Figure 3



figure 4

Steps to secure the wheelchair user:

1. Remove both arm rests.
2. If present, attach the wheelchair's pelvic belt.
3. Attach the occupant restraint belts according to the instructions of the strap-system manufacturer.
4. Wear the pelvic belt low across the front of the pelvis, so that the angle of the pelvic belt is within the preferred zone of 30° to 75° to the horizontal, similar to that shown below.

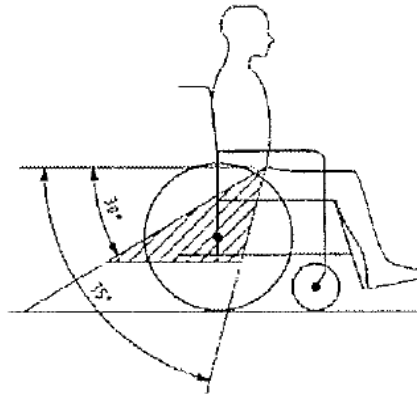

5. A steeper (greater) angle within the preferred zone is desirable.
6. Adjust the belt tightly according to the instructions of the strap-system manufacturer, consistent with the user's comfort.
7. Ensure that the restraint belt connects in a straight line to the anchor point in the vehicle and that no bends in the belt are visible, for instance at the axle of the rear wheel.
8. Install the arm rests, if desired. make sure that belts are not twisted or held away from the body by wheelchair components such as arm rests or wheels.

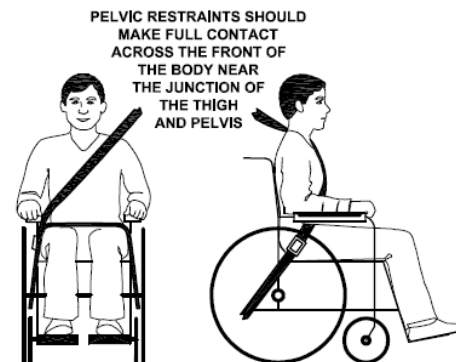

3 Installation and adjustment

The instructions in this chapter are for the specialist dealer.

The Vermeiren D200 has been designed to be adjust with a minimum of replacements parts. There is no need for extra stock of spare parts.

To find a service facility or specialist dealer near you, contact the nearest Vermeiren facility. A list of Vermeiren facilities can be found on the last page.

⚠ WARNING: Risk of unsafe settings - Use only the settings described in this manual.

⚠ WARNING: Variation of allowed adjustments can still change the stability of your wheelchair (tilt back or sideways).

3.1 Tools

To set up the wheelchair the following tools are needed.

- Wrench set n° 7 to n° 22
- Allen key set n° 3 to n° 8
- Screwdriver n° 4 to n° 5
- Screwdriver Phillips head

3.2 Manner of delivery

The Vermeiren D200 shall be delivered with:

- 1 frame with armrests, rear and front wheels (seat height of 500 mm)
- 1 pair footrests
- Tools
- Manual
- Accessories

3.3 Adjusting the seat height

The Vermeiren D200 is adjustable in 3 seat heights by changing the wheels position. At each height there is a different setting of the front and rear wheels.

⚠ WARNING: The top hole of the axle plate is not intended for mounting the rear axle - This hole is for mounting the drum brake.

Seat height	Rear wheel	Front wheel
470 mm	Hole 1 and Hole 2	Hole A
500 mm (Standard)	Hole 2 and Hole 3	Hole B
530 mm	Hole 3 and Hole 4	Hole C

Table 2: Seat heights

Change the seat height according the following steps:

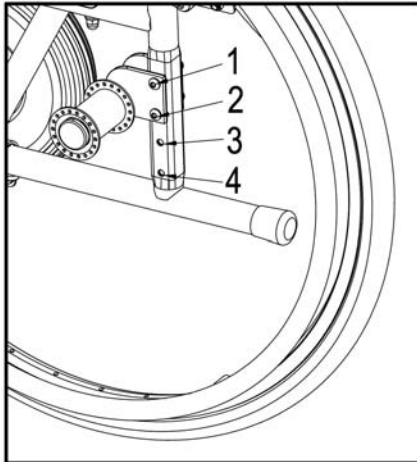

1. Remove the rear wheels (see § 2.13).
2. Remove the screw from the plate.
3. Assemble the plate in the right hole of the side frame, see Table 2.
4. Check if the axle bushings are fastened well.

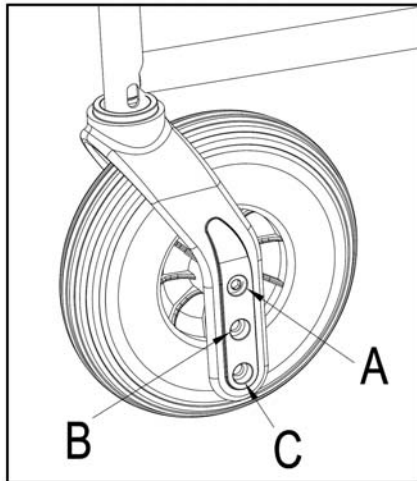

5. Remove the screw from the front fork and wheels.
6. Place it according table 2.
7. Install the front wheels and tighten it. Check if it turn smoothly, but there is no space for motion.
8. Mount the rear wheels.
9. If installed properly the fork of the front wheels and the ground must be perpendicular. Check this.
10. Adjust the brakes according § 3.4.

3.4 Adjust the brakes

⚠ WARNING: Risk of injury – Brakes may only be adjusted by your specialist dealer.

Adjust the brakes according following rules:

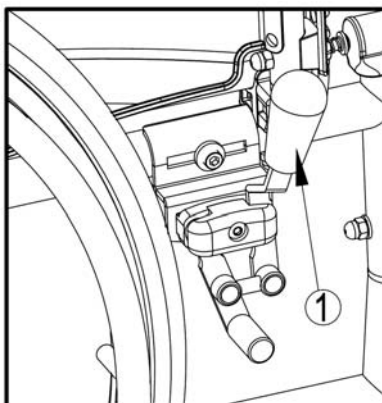

1. Install the wheels according § 2.2.
2. Disconnect the brakes by pulling lever ① backwards.

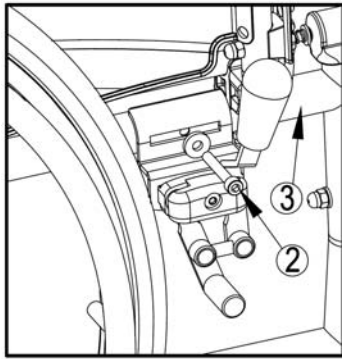

3. Loosen the bolts ② so the brake mechanism can slide over the guide ③.
4. Pull the brake mechanism over the guide ③ to the desired position.
5. Retighten the bolts ②.
6. Check working of the brakes.
7. If necessary repeat the above steps until the brakes are adjusted well.

3.5 Adjusting of the footrest

3.5.1 Length of the footrest

⚠ CAUTION: Risk of damage – Avoid that the footplate make any contact with the ground. Keep a minimum distance from 60 mm above the ground.

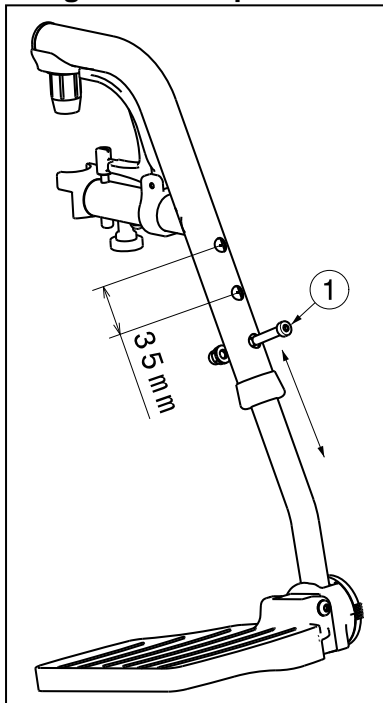

Adjust the length of the footrest as follow (3 positions possible: steps 35 mm → holes outside tube, 6 positions possible: steps 25 mm → inner tube):

1. Remove the screw ①.
2. Adjust the length of the footrest to a comfortable length.
3. Tighten the screw ① properly.

3.5.2 Adjusting angle footplates

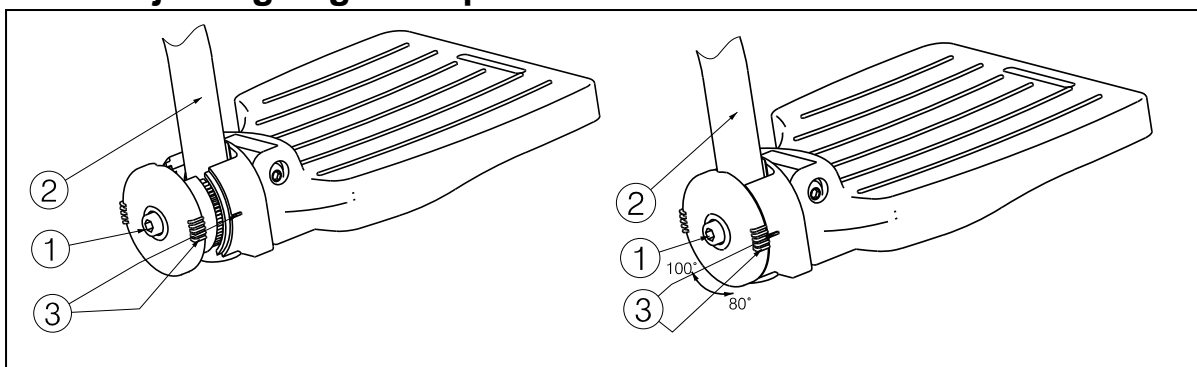

Adjust the angle of the footplates as follow:

1. Loosen bolt ①.
2. Adjust tube ② in the desired angle. The angle indication (80°-85°-90°-95°-100°) is according the dashes ③.
3. Retighten the bolt ①.

3.6 Adjusting the armpad

The armpad of your wheelchair is adjustable in height and depth. The height of the armpad can be adjusted in 3 positions.

Height armpad to seat	Number of the blocks under the tube	Number of blocks between tube and armpad
220 mm (Standard)	2	1
230 mm	1	2
240 mm	0	3

Table 3: Height of armpad

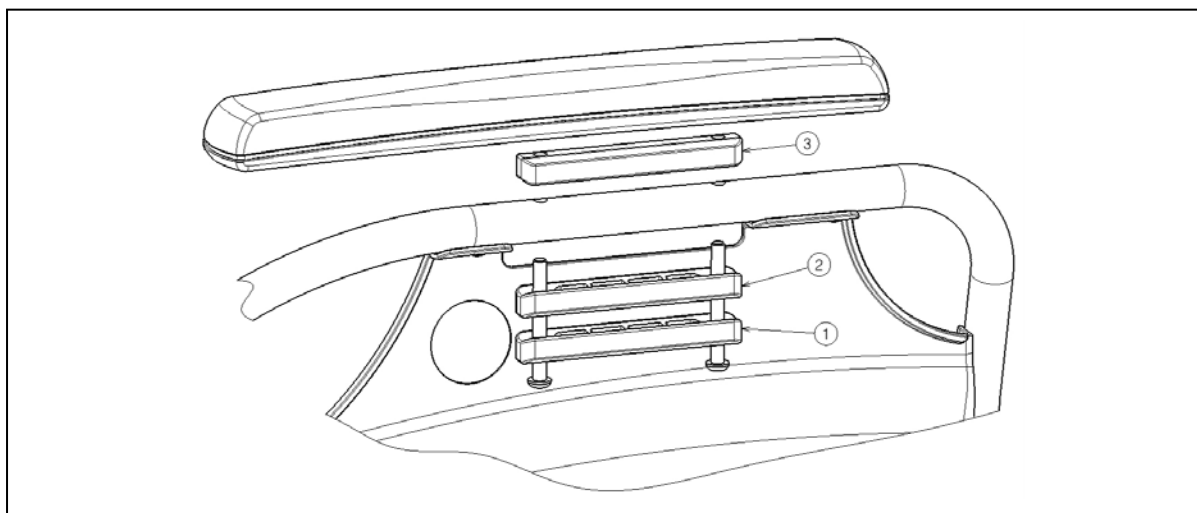

The depth of the armpad can be adjusted in 3 positions.

Depth of the armpad	Used holes
Front position	Back and middle
Middle position (Standard)	Hole 2 and 4
Back position	Front and middle

Table 4: Depth of armpad

Adjust the height and the depth of the armpad as follow:

1. Remove both screws under the armpad.
2. Place the correct number of blocks under and above the tubes, see table 3.
3. Install the armpad with the required holes for depth adjustment.

4 Maintenance

For the maintenance manual of the wheelchairs refer to the Vermeiren website:
www.vermeiren.be.



SERVICE

The manual wheelchair was serviced:

Dealer's stamp:

Date:

Dealer's stamp:

Date:

Dealer's stamp:

Date:

Dealer's stamp:

Date:

Dealer's stamp:

Date:

Dealer's stamp:

Date:

Dealer's stamp:

Date:

Dealer's stamp:

Date:

Dealer's stamp:

Date:

Dealer's stamp:

Date:

- For service checklists an additional technical information, please see our specialist dealers nearest to you. More information on our website at: www.vermeiren.com.

Belgium

N.V. Vermeiren N.V.

Vermeirenplein 1 / 15
B-2920 Kalmthout
Tel: +32(0)3 620 20 20
Fax: +32(0)3 666 48 94
website: www.vermeiren.be
e-mail: info@vermeiren.be

France

Vermeiren France S.A.

Z. I., 5, Rue d'Ennevelin
F-59710 Avelin
Tel: +33(0)3 28 55 07 98
Fax: +33(0)3 20 90 28 89
website: www.vermeiren.fr
e-mail: info@vermeiren.fr

Italy

Vermeiren Italia

Viale delle Industrie 5
I-20020 Arese MI
Tel: +39 02 99 77 07
Fax: +39 02 93 58 56 17
website: www.reatime.it
e-mail: info@reatime.it

Poland

Vermeiren Polska Sp. z o.o

ul. Łączna 1
PL-55-100 Trzebnica
Tel: +48(0)71 387 42 00
Fax: +48(0)71 387 05 74
website: www.vermeiren.pl
e-mail: info@vermeiren.pl

Czech Republic

Vermeiren ČR S.R.O.

Nadrazni 132
702 00 Ostrava 1
Tel: +420 596 133 923
Fax: +420 596 133 277
website: www.vermeiren.cz
e-mail: info@vermeiren.cz

Germany

Vermeiren Deutschland GmbH

Wahlerstraße 12 a
D-40472 Düsseldorf
Tel: +49(0)211 94 27 90
Fax: +49(0)211 65 36 00
website: www.vermeiren.de
e-mail: info@vermeiren.de

Austria

L. Vermeiren Ges. mbH

Winetzhammerstraße 10
A-4030 Linz
Tel: +43(0)732 37 13 66
Fax: +43(0)732 37 13 69
website: www.vermeiren.at
e-mail: info@vermeiren.at

Switzerland

Vermeiren Suisse S.A.

Hühnerhubelstraße 59
CH-3123 Belp
Tel: +41(0)31 818 40 95
Fax: +41(0)31 818 40 98
website: www.vermeiren.ch
e-mail: info@vermeiren.ch

Spain / Portugal

Vermeiren Iberica, S.L.

Carratera de Cartellà, Km 0,5
Sant Gregori Parc Industrial Edifici A
17150 Sant Gregori (Girona)
Tel: +34 972 42 84 33
Fax: +34 972 40 50 54
website: www.vermeiren.es
e-mail: info@vermeiren.es