



HFL-300
(150 kg. capacity)

HFL-300

USER MANUAL

INDEELIFT, S.L.
BARCELONA, SPAIN
international@indeelift.com
www.IndeeLift.com

HFL-300 User Manual



Please read this entire manual *before* using the product and retain for future reference. NOTE: Users should also view the “IndeeLift HFL-300 Training Video”, available on IndeeLift’s YouTube channel.

TABLE OF CONTENTS

HFL-300

Introduction:	2
Overview:	2
HFL Features/Functionality:	3
Small Footprint and Easy Portability	3
Mounting Ramp Seat	3
Wired Remote	3
Adjustable and/or Removable Rise Handles	3
Rechargeable Battery	3
HFL-300 Component Identification:	4
Preparing the HFL- 300 for Use:	5
Unpacking the HFL- 300:	5
Charging the Battery:	6
Operation:	7
Self-Operation:	7
Assisted Operation – Standard Lift:	8
Maintenance:	9
Troubleshooting / Service:	9
Warranty Information:	9
Specifications	10
Physical Specifications:	10
Electrical Specifications:	10
APPENDIX A: HFL-300-D Information	11

IndeeLift – the first Human Floor Lift designed and engineered to alleviate the grief, hazards and hassles of recovering from a fall!

HFL-300 User Manual

Introduction:

IndeeLift's patented line of Human Floor Lifts (HFLs) are a class of human lifts unlike any other available. This family of products has been designed to assist individuals who have fallen to the floor and are unable to get up without assistance. The rugged and reliable IndeeLift HFLs are purpose-built appliances designed in the USA and manufacture in Spain with CE, UL and ETL certified components and are available in consumer/ small business, professional healthcare, and emergency medical services models.

The HFL-300 are Human Floor Lifts designed for self or assisted operation in the home or business. These appliances can lift a person from the floor without risk of injury to the fallen or anyone assisting them. As a fall recovery appliance, these HFLs are extremely maneuverable and their small footprint allows fall recovery to occur in even the tightest of places. The HFLs replace large and cumbersome sling-style lifts, helping fallen people to recover and get back on their feet quickly, while greatly reducing the associated risks.

NOTE: These HFLs are also available with seat belts option (HFL-300-D), which are identical to the HFL-300 with the inclusion of waist and chest belt anchor points and belt assemblies for additional safety when lifting individuals. *See Appendix A for more information.*

Overview:

This manual covers the HFL-300 consumer models which are designed for use in the home and small businesses, (such as hospices). They provide the same features, functions and operational characteristics except for rated capacity. The HFL-300 is engineered to lift a person of up to 150 kg. This unit is referred to as the "HFL" throughout this manual.

The HFL is operated with a wired remote control in a portable "roll-around" configuration. This state-of-the-art product was designed to easily lift mobility challenged individuals from the floor and can be self-operated or operated with the assistance of a helper, without injury to the fallen person or any helper.

Self-Operation: After a fall, the fallen person scoots over to the HFL, slides or tilts up onto the mounting ramp seat, pushes a button on the wired remote, activating the motor which raises them from the floor.

Assisted Operation: A helper can easily wheel the HFL to the fallen person and assist them onto the mounting ramp seat, if necessary. The helper then pushes a button on the wired remote, activating the motor which raises the fallen person from the floor.

Once up from the floor, the fallen person can take a deep breath and rest comfortably until they are ready to stand up and walk away or be directly transferred to a wheelchair, all without the risk of injuries related to the fall recovery.

IndeeLift HFLs are covered by US and international patents including US 9,808,388 and EURO PAT 3151803

HFL-300 User Manual

HFL Features/Functionality:

The raised-seat height was dictated by the need to stand from the floor with minimal effort. The ability to transfer directly to a wheelchair is accomplished by setting the seat height at 53 cm which allows a height difference of 2-5 cm for lift-free transfers to most wheelchairs.

Small Footprint and Easy Portability

The HFL is a portable lift that is rolled around on wheels like a traditional dolly. The small footprint allows it to be positioned in many places other lifts simply cannot go. With a turning radius of 81 cm, the HFL can go just about anywhere including all accessible bathrooms, as well as most other bathrooms.

Mounting Ramp Seat

The HFL patented design includes a mounting ramp seat that eliminates the need to ever "lift" a person manually. A user either scoots onto the lift using the front ramp or they can tilt up onto the seat with no complex cradles or harnesses to configure -- the HFL allows fall recovery to be simple and quick. A person who has fallen can be up from the floor to a normal seated position within one minute.

Wired Remote

The wired remote has a 1.5m retractable cord, allowing the user or a helper to operate the lift. The wired remote has graphics indicating the up and down functionality. The wired remote is stored on the HFL's handles with the hanger clip.

Adjustable and/or Removable Rise Handles

The rise assist handles have been engineered to provide leverage for the seated party to assist in the process of standing once they are up from the floor. The arms can swing away from the seat if needed. They are also removable to allow for mount assistance or a direct transfer to a wheelchair or other destination -- with no lifting required.

Rechargeable Battery

The HFL comes standard with a self-contained rechargeable Lithium-Ion battery pack and charging unit. The HFL will operate at less-than-optimum performance when in need of charging. Charging is accomplished by plugging the charging unit's AC power cord into a standard AC wall power outlet, (see **Preparing the HFL 300 for use** on Page 5). A full charge takes about eight hours.

NOTE: Lithium-Ion batteries offer light weight, high energy density, low memory effect and long-life. The charger automatically shuts off when charging is complete, which prevents over-charging. The battery should be charged in a clean, dry location, away from direct sunlight, sparks or flame. Failure to recharge the battery at least once every three months *may* result in the battery no longer accepting a charge. The battery should be fully charged before storing the HFL for extended periods. At some point in the future when the battery needs replacing, please dispose of the old battery at a recycling center.

HFL-300 User Manual

HFL-300 Component Identification:

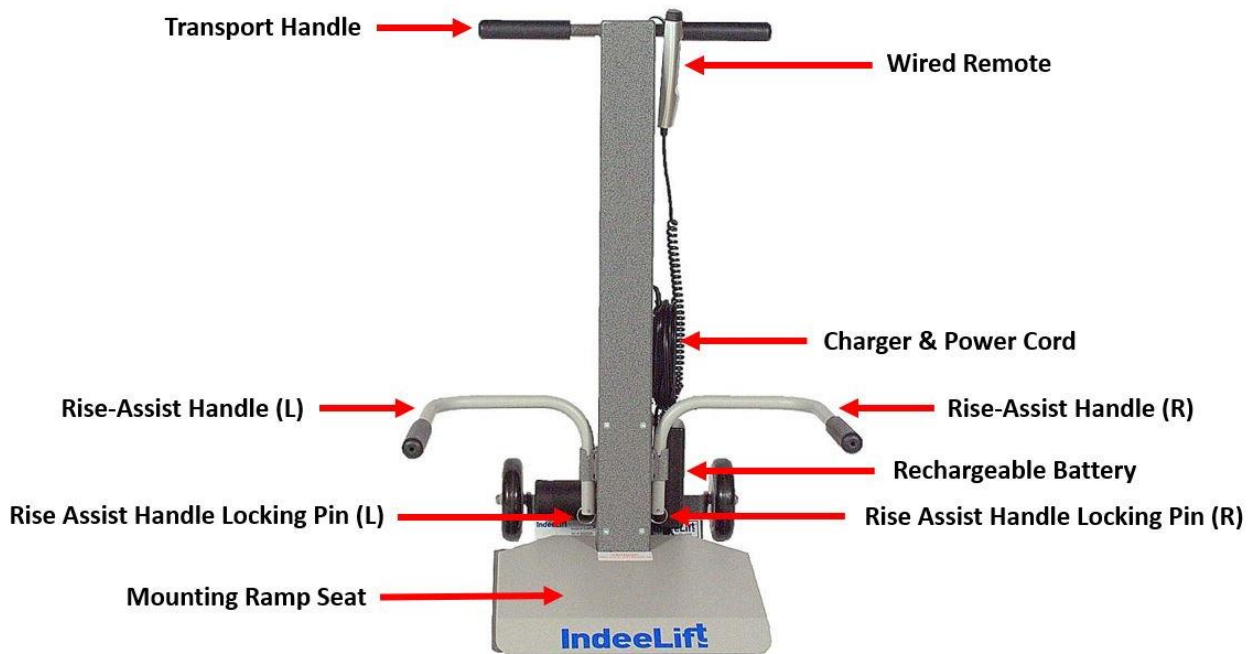

Components and Controls:

Wired Remote

The wired remote control is connected to the HFL with a coiled cord and is used to raise and lower the seat by pressing the up or down button. Raising or lowering the seat takes approximately 60 seconds. The wired remote has graphics indicating the up and down functionality. The wired remote is generally stored on the HFL's handles with the hanger clip.

*Note: If intended for self-operation, the wired remote should be stored on one of the rise assist handles (see **Self-Operation** on Page 7).*



Rise Assist Handles

The rise assist handles provide support when standing from the seat. If desired, they can be swung away from the seat by lifting on them, then moving them away from the seat. They are also removable to allow a direct transfer to a wheelchair or other destination. *To remove a rise assist handle, remove the locking pin at the bottom of the handle, (as shown), then lift the handle upward.*



HFL-300 User Manual

Preparing the HFL- 300 for Use:

Unpacking the HFL- 300:

The HFL comes packaged for shipment in a carton that is sealed with shipping tape. *The unit ships without the wheels attached.* Packed inside the shipping carton will be the HFL, user manual and a box containing the wheel components, instruction sheet and wrench, as well as the AC power cord that connects to the battery charger. NOTE: HFL-300-D units also ship with two safety belt assemblies and a column-mounted storage bag for the belts, (see **Appendix A** for more information on the HFL-300-D units).

- Cut or remove the shipping tape on the top flaps of the carton.
- Stand the packing carton with the heavy end down.
- Open the box and remove the foam and cardboard shipping reinforcement inserts.
- Remove the box containing the wheel components and the AC power cord.
NOTE: The -D units have an additional bag in the box containing two safety belt assemblies.
- Remove the HFL and place it in an upright position on the floor.
- Attach the wheels by following the instructions found in the box with the wheel components and wrench.
- Remove the wired remote from its protective bag.
- Test the HFL by raising and lowering the seat using the wired remote's up and down buttons.
- Properly dispose of the packaging materials.

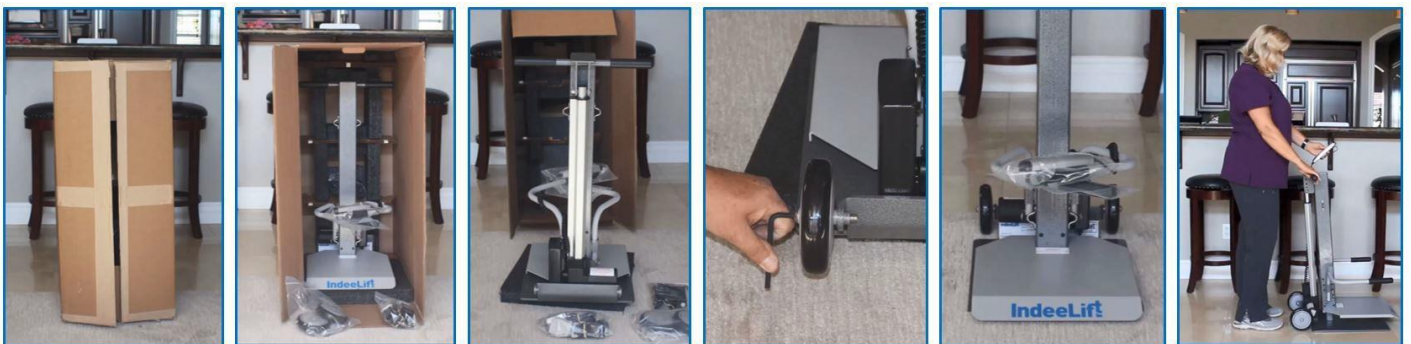

NOTE: If the unit is intended for self-operation, use the hanger clip on the back of the wired remote to place it on one of the lower rise assist handles. If the unit is intended for assisted operation, place the wired remote on one of the upper transport handles.



HFL-300 User Manual

Charging the Battery:



It is recommended that the HFL be fully charged *before* its first use.

1. Position the HFL near a standard commercial AC wall power outlet.
2. Attach the female end of the AC power cord to the connector on top of the HFL's battery charger.
3. Attach the male end of the AC power cord to a standard commercial AC wall power outlet.

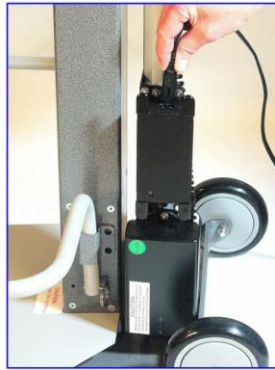

- The green LED on the battery charger becomes lit and, within 15 seconds, the orange LED on the battery begins to flash. *This indicates that the battery is charging.*
- After an initial charge of up to eight hours, the battery is fully charged and the orange LED on the battery stops flashing.
- Once the unit is fully charged, disconnect the male end of the power cord from the AC wall power outlet, leave the female end attached to the battery charger and wrap the cord around the charger, (as you would on an upright vacuum cleaner).



Green LED (Charger)

Orange LED (Battery)



NOTES:

When the HFL's battery is running low, it will emit a steady tone when pressing the up or down button on the wired remote. This indicates that it's time to recharge the battery. Each charge is good for at least 10 lifts, depending on the weight of the person being lifted. If you need to use the HFL when the battery requires charging, or if the battery fails to operate the HFL, the lift can be operated with the power cord connected to an AC wall outlet.

HFL-300 User Manual

Operation:



Ensure that any users are thoroughly familiar with the correct operation of the HFL- 300 *before* they use it to lift themselves or someone else.

Continuous lift cycles may overheat the motor. To avoid this, a 15 min waiting time between each lift is recommended.

Self-Operation:

While the assistance of a helper can be useful, the HFL home models are designed to be self-operated. It is recommended that you keep the HFL in a location easily accessible within the home (i.e., in a place where a fallen person can scoot to it when needed).

1. Keep the seat in the downward (home) position with the wired remote clipped to one of the rise assist handles, as shown below.
2. After a fall, scoot yourself backwards onto the HFL's mounting ramp seat.
3. Once fully seated in the center and to the rear of the HFL's seat, press the "up" button on the wired remote. The motor engages and smoothly raises the seat to a height of 53 cm, then automatically stops. *NOTE: This takes about one minute.*
4. Once the seat stops in the fully raised position, rest and catch your breath if needed. Then clip the wired remote back onto one of the handles.
5. Ensure your feet are properly positioned for standing, then use the rise-assist handles to steady yourself.
6. Stand up, as you would from any chair.



NOTE: Once you are back on your feet, return the seat to the fully downward (home) position and clip the wired remote to one of the rise assist handles, (so it will be ready to use again when needed).



ALWAYS ENSURE THERE ARE NO FOREIGN OBJECTS BELOW THE SEAT *BEFORE* LOWERING IT TO THE HOME POSITION AND BEFORE TITLTING THE HFL BACK TO AN UPRIGHT POSITION IN ITS STORED LOCATION!

HFL-300 User Manual

Assisted Operation – Standard Lift:

If available, a helper can assist a fallen person. When used for assisted operation, it is recommended that the seat be raised to a height of 15 to 20 cm from the floor *before* transporting it to the location of the fallen person. *This will make it easier for the helper to move the unit.*



1. Stand behind the HFL and place one foot on the back of the unit. Then gently tilt the HFL backwards by pulling the handle towards you. You can now pull or push to HFL to the fallen person.



As you stop at the desired location, ensure there are no foreign objects beneath the seat *before* lowering the seat or tilting the unit back to the upright position.

NEVER ATTEMPT TO TRANSPORT A PERSON WHILE THEY ARE SEATED ON THE HFL.

2. Once you arrive at the location of the fallen person, lower the seat to its fully downward position, temporarily place the wired remote on the upper transport handle, then position the HFL directly behind the fallen person, with the mounting ramp seat as close to the fallen person's buttocks as possible.
3. Have the fallen person scoot themselves backwards into the mounting ramp seat, assisting them if needed. NOTE: If the fallen person has difficulty scooting backwards onto the mounting ramp seat, you can use the **Mount Assist Procedure**, on Page 9.
4. Once the fallen person is fully seated in the center and to the rear of the HFL's seat, have them place their hands on the rise assist handles and let them know you are about to raise the seat. When they are ready, press and hold the up button, as indicated by the arrow on the wired remote. The seat will rise for approximately one minute, then automatically stop.
5. When the HFL has stopped, allow the recovered person to catch their breath and rest if needed, then place the wired remote back on the HFL's upper transport handle and offer the recovered person your hand.
6. Ensure the recovered person's feet are properly positioned for standing, then assist them, if needed, as they stand up from the seat.



NOTE: Once the fallen person has been recovered and is no longer near the unit, it is recommended that the seat be lowered to a height of 15 to 20 cm from the floor to make it easier to transport the unit back to its stored location. Then leave the seat in this position, so it is easy to transport the unit the next time it is needed.

HFL-300 User Manual

Maintenance:

The IndeeLift HFL requires no regular maintenance. All exposed surfaces can be cleaned with standard cleaning products. Keeping the battery charged helps improve battery life.

Note: While the HFL is extremely durable and will perform well indoors or outdoors, it is recommended that the HFL be stored indoors when not in use.

Troubleshooting / Service:

The HFL-300 was designed to provide years of trouble-free performance. There are no user serviceable parts. However, should you encounter a situation where the unit is not operating properly, please ensure you have correctly followed the procedures for recharging the unit (covered in the **Charging the Battery** section of this manual on Page 6).

If charging the unit does not resolve the problem, or if you encounter any other operational issues with this unit, please contact your local reseller. Our knowledgeable associates will help to diagnose the problem and present a plan for swift resolution.

You can also send us an email at international@indeelift.com with your model number, serial number, purchase date and a detailed description of the problem.

Warranty Information:

IndeeLift SL warrants to the original purchaser that this product and the components thereof will be free from defects in workmanship and materials for a period of **two year** from the original date of purchase. IndeeLift SL will, without charge, repair or replace at its option, any defective components or the whole product if necessary. Shipping charges may apply. If a total replacement is necessary, IndeeLift, may upon its discretion provide the latest model, which meets or exceeds the specifications of the product to be replaced.

Exclusions:

This warranty does not apply in the event of misuse or abuse of the product or as a result of unauthorized alterations or repairs. IndeeLift Inc. reserves the right to make changes in design or make additions or improvements to this product without any obligation to install the same on products previously manufactured.

IndeeLift Inc. shall not be liable for any consequential damages including, without limitations, damages resulting from loss of use. Some states do not allow limitations of incidental or consequential damages, so the above limitation or exclusion may not apply to you. The warranty gives you specific rights and you may have other rights, which vary from state to state.

HFL-300 User Manual

Specifications

Physical Specifications:

Safe Working Load **150 kg**
Wheels 12.5 cm
Unit Weight 28.5 kg

Shipping box weight 34 kg
Shipping box dimensions 98 x 44 x 66 cm

Electrical Specifications:

110-240 VAC 50-60 Hz Operating
environment: >+5°C <+40°C

	cm
A	38
B	53
C	57
D	53
E	80
F	127

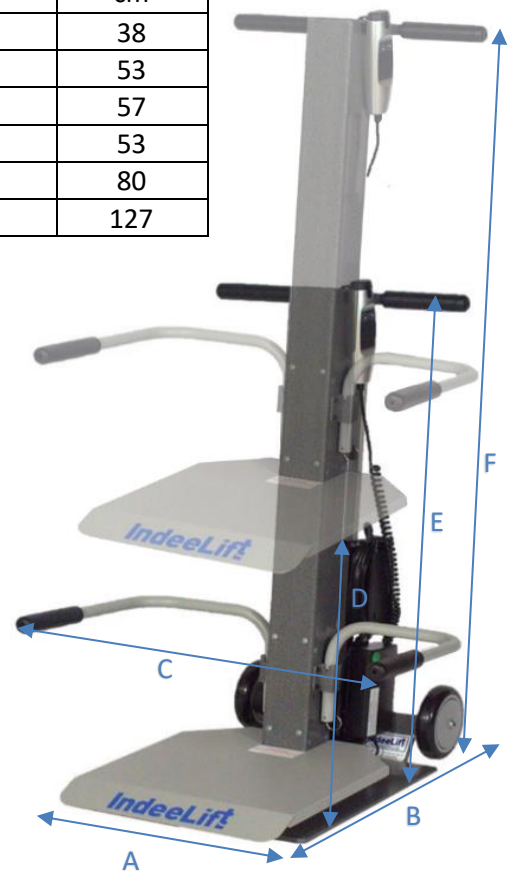

HFL-300 User Manual

APPENDIX A: HFL-300-D Information



Please read the entire manual, (including this appendix), *before* using the HFL-300-D and retain for future reference.

Overview:

This appendix covers the additional features of the HFL-300-D models. These units are identical to the HFL-300 with the inclusion of upper belt anchor points, (left and right), and lower belt anchor points, (left and right), located on either side of the HFL's main column, two sets of belt assemblies which can be used together as waist and chest belts to secure the fallen person to the lift as needed, and a column-mounted ripstop nylon storage bag for the belt assemblies.

The anchor points and belt assemblies are for use when lifting an individual who has minimal upper and lower body strength. NOTE: The belt assemblies can also be used simply as desired for additional safety when lifting an individual.

All procedures that do not involve the use of the waist and chest belt accessories are covered in detail earlier in this Users' Manual and are *fully applicable* to the HFL-300-D units.

HFL-300-D / Component Identification:

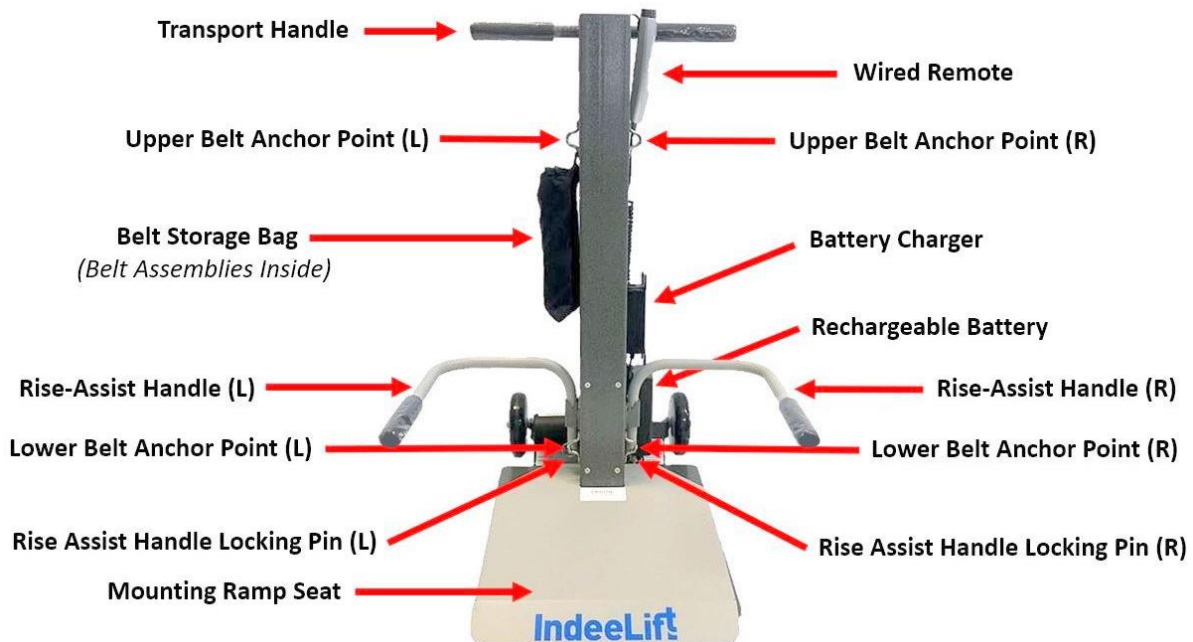

HFL-300 User Manual

Using the Belt Assemblies:

Each belt assembly includes two straps; the longer strap has a seatbelt style *buckle* with a snap hook at the end, the shorter strap has a seatbelt style *clasp* with a snap hook at the end. Each of the two straps form a single belt assembly. NOTE: The two belt assemblies are identical, (*either assembly can be used as a chest belt or a waist belt*).

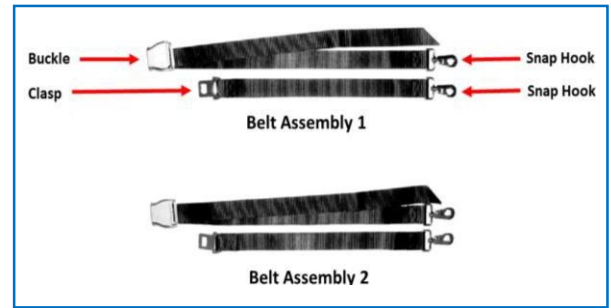

In use, they are secured to the HFL's upper and lower belt anchor points, (located on the HFL's main column), using snap hooks at the end of each belt assembly. The upper belt assembly and anchor points can be used as a chest belt and the lower belt assembly and anchor points can be used as a waist belt. When not in use, they are rolled-up and placed in the column-mounted storage bag.



Upper Anchor Points



Lower Anchor Points



Using the Snap Hooks to Attach the Belt Assemblies



Belts in Storage Bag

NOTE: Depending on the circumstances, you may choose to use the waist belt only. The anchor points and belt assemblies also allow for additional configurations, (such as crossing the chest of the person being lifted by attaching one belt assembly to the upper left and lower right anchor points and the second belt assembly to the upper right and lower left anchor points).

Once the fallen individual is securely buckled to the lift using the belt assemblies, pull on each buckles' strap to ensure both belts are snug and secure *before* pressing the up button on the wired remote. As the seated person is being lifted, have them gradually move their legs inward, then ensure their feet are properly positioned *before* they stand up from the HFL's seat, (as the would from any chair).



HFL-300 User Manual

This Page Intentionally Left Blank