

TECHNICAL FILE

PRODUCT RANGE: KING

CODE: KING-STR-00

DESCRIPTION: ROUND SHOWER STOOL KING

PRODUCT FEATURES:

The round KING bathroom stool is designed for those who want to increase their comfort while showering and carrying out different hygiene operations in the bathroom. The ergonomically designed surface area of the seat reduces pressure, increasing user comfort. The anti-slip pattern of the seat surface prevents sliding during the hygiene operation to ensure maximum safety. The seat is made of polypropylene offering durability, strength and warmth. The frame is made of anodized aluminium to ensure the best resistance against corrosion. All the surfaces are easy to clean.

MECHANICAL PERFORMANCE:

Max user weight 175 kg; 385 lbs.

CERTIFICATIONS:

CE Declaration of conformity of the European Directive for Medical Device 93/42 EEC.

APPLICABLE NORMS:

UNI EN 12182; UNI CEI EN ISO 14971; UNI EN 1041.

MAINTENANCE:

Periodically check that fixing fittings conform to initial mounting.
Clean with water and non-aggressive detergent.
Do not use abrasive or corrosive products.

PRODUCT PACKAGING:

Box dimensions: 369x308,5x76 mm.
Gross weight: 1.410 kg
Net weight: 1.110 kg
Shipping carton dimensions: 853x388x364 mm.

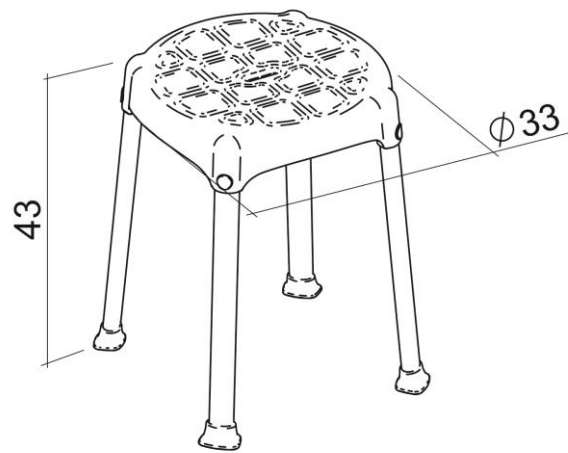

PACKAGING COMPONENTS	Q.TY	CODE
Box	1	RB-KINGSTRA-00
Shipping Carton	1/10	SC-KINGSTRA-00
Box Label	1	BL-BKINGSTR-00
Shipping Carton Label	1/10	BL-CKINGSTR-00

PRODUCT COMPONENTS	Q.TY	MATERIAL	REF.
Seat	1	Polypropylene 30% CC	1
Legs	4	Anodized Aluminium	2
Plastic Pin	4	Polyethylene	4
Plastic Caps	4	Polypropylene	3

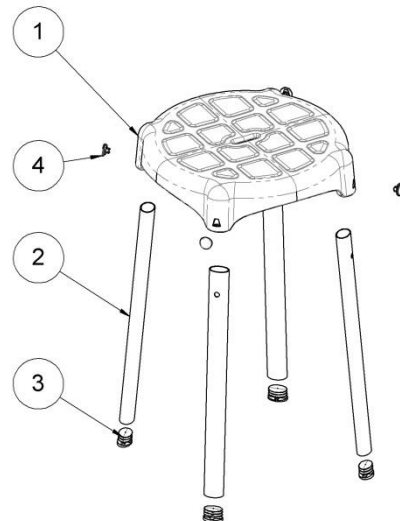

The above data cannot be binding. LM Global Design Ltd. reserves itself the right to make technical or aesthetic modifications without notice at any time.