

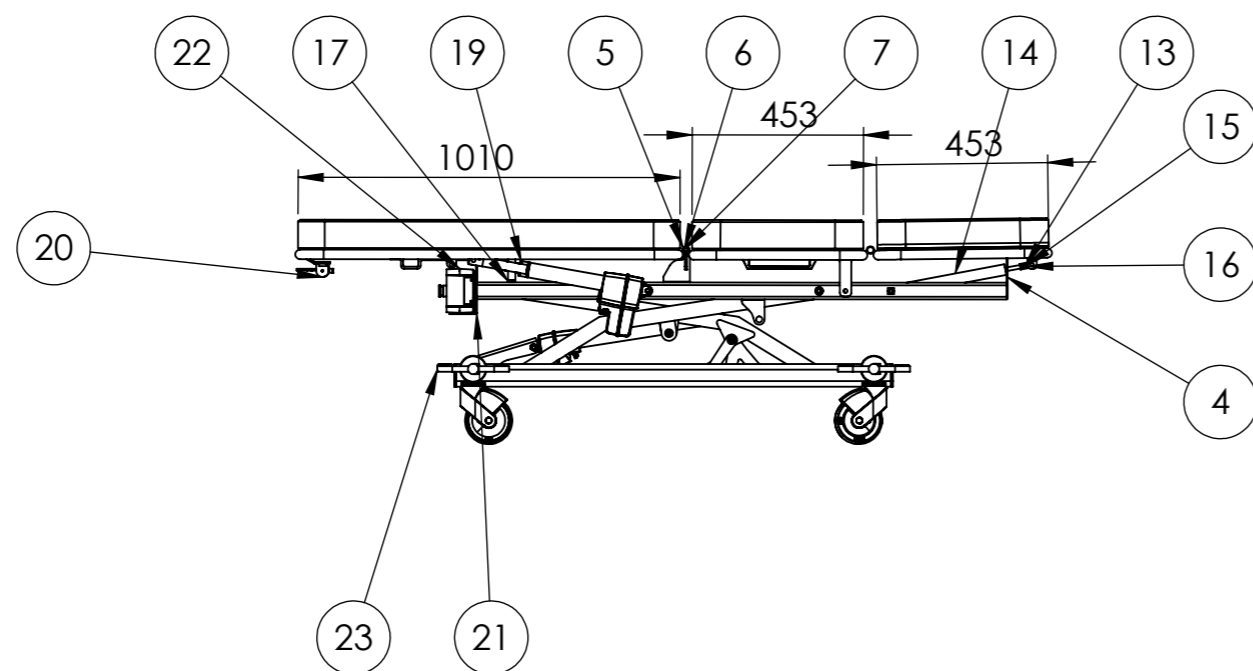

ITEM NO.	PART NUMBER	Description	QTY.
1	L-25000	Hjulramme delsamling	1
2	W6-1100	Topramme 3-delt	1
3	U6-400	Rygstykke 1000mm	1
4	L33-13	Stop for liggeflade	1
5	L40	Bøsning plast	7
6	L16-4	Afstandsør	2
7	DIN EN ISO 7040 - M10 - N		2
8	L53-H	Glideklods	1
9	F3-100	Ryg stykke	1
10	F5-100	Ryg stykke	1
11	F3-2-70	Ryg del 100cm	1
12	F4	Hynde ryg fys	2
13	GAS-02-stempelstang		1
14	GAS-01	Gasfjeder 150N	1
15	GFHANDTAG	Håndtag for gasfjeder	1
16	GFUDLOSERH OVED	Udløserhoved for gasfjeder	1
17	ø20 prop	Plastprop	2
18	LA40-180		1
19	MOT-38	Løftemotor MOT-38	1
20	udløsergreb	Udløsergreb	1
21	bat-skærm	Skærm til Batteri	1
22	Jumbo	CBJ styring	1
23	Pedal-højre	Bremsepedal	1
24	Pedal-venstre	Bremsepedal	1
25	hbtgreb	Ophæng til HBT	2

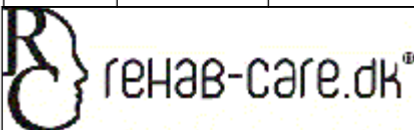

Rev	Date	Description
		Scale: 1:10
		Paper: A3
		Sheet 1 of 2
Description: Genoptrænings leje 70cm bred		
Surface treatment:		Color:
Drawn By: MG	Drawn Date: 18-11-19	
Weight: 191853.62	State: - ok	Material:
		Drawing No.: FYS-hammel Rev.

