



APPLICATION FOR CE REPORT

On Behalf of

Shanghai Wisking Electric Machine Co., Ltd.

MOBILITY SCOOTER

**Model: Wisking4011, Wisking4012, Wisking4013, Wisking4014,
Wisking4015, Wisking4016, Wisking4017, Wisking4018,
Wisking4019, Wisking4020, Wisking4021, Wisking4022,
Wisking4023, Wisking4024, Wisking4025, Wisking4026,
Wisking4027, Wisking4028, Wisking4029, Wisking4030,
Wisking4031, Wisking4031, Wisking4033, Wisking4034,
Wisking4035, Wisking4036, Wisking4037, Wisking4038,
Wisking4039, Wisking4040**

**Prepared For: Shanghai Wisking Electric Machine Co., Ltd.
No.168, Pinggang Road, Situan Town, Shanghai, China**

**Prepared By: Shenzhen STONE Testing Technology Co., Ltd.
East of F/4, Bldg. 11B, Area A, Tanglang Industrial Park,
Taoyuan Street, Nanshan District, Shenzhen, Guangdong, China**

Date of Test: Nov. 21, 2014 to Nov. 27, 2014

Date of Report: Nov. 28, 2014

Report Number: STT20141128693S



TEST REPORT
EN 12184
Electrically powered wheelchairs, scooters and their chargers -
Requirements and test methods

Report Reference No......: STT20141128693S
Tested by (name+signature): Andy Huang *Andy Huang*
Approved by (name+signature).....: Ethan Chen *Ethan Chen*
Date of issue.....: Nov. 28, 2014

Testing Laboratory: Shenzhen STONE Testing Technology Co., Ltd.
Address: East of F/4, Bldg. 11B, Area A, Tanglang Industrial Park, Taoyuan Street, Nanshan District, Shenzhen, Guangdong, China

Applicant's name: Shanghai Wisking Electric Machine Co., Ltd.
Address: No.168, Pinggang Road, Situan Town, Shanghai, China

Test specification:
Standard: EN 12184: 2009
Test procedure: CE Produce
Non-standard test method.....: N/A

Test Report Form No......: EN12184-V02
Test Report Form(s) Originator: STT
Master TRF.....: 2013-08

Test item description : MOBILITY SCOOTER

Brand Mark: wisking
Manufacturer: Shanghai Wisking Electric Machine Co., Ltd.
Address.....: No.168, Pinggang Road, Situan Town, Shanghai, China
Model/Type reference.....: Wisking4011, Wisking4012, Wisking4013, Wisking4014, Wisking4015, Wisking4016, Wisking4017, Wisking4018, Wisking4019, Wisking4020, Wisking4021, Wisking4022, Wisking4023, Wisking4024, Wisking4025, Wisking4026, Wisking4027, Wisking4028, Wisking4029, Wisking4030, Wisking4031, Wisking4031, Wisking4033, Wisking4034, Wisking4035, Wisking4036, Wisking4037, Wisking4038, Wisking4039, Wisking4040



Test case verdicts

Test case does not apply to the test object: N/A (Not Applicable)

Test item does meet the requirement.....: P(ass)

Test item does not meet the requirement.....: F(ail)

General remarks

This test report shall not be reproduced except in full without the written approval of the testing laboratory.

The test results presented in this report relate only to the item tested.

“(See remark #)” refers to a remark appended to the report.

“(See appended table)” refers to a table appended to the report.

Throughout this report a comma / point is used as the decimal separator.

General product information:

SPECIFICATIONS ↕	
Drive Wheels: ↕	16in, pneumatic ↕
Front Wheels: ↕	14in., pneumatic↕
Anti-tip Wheels: ↕	3in., solid,↕
Maximum Speed: ↕	15-17km/h↕
Brakes: ↕	"Intelligent Braking" electronic regenerative, disc park brake ↕
Overall Size: ↕	Length: 55.2 in. ↕
↕	Width: 26.3 in. ↕
Seating Options: ↕	Medium-Back Seat (standard) ↕
↕	Limited Recline High-Back Seat (optional) ↕
↕	Full Recline High-Back Seat (optional) ↕
Drive train: ↕	One 1200W motor↕
Batteries: ↕	12V/75AHx2 or 12V/100AHx2 ↕
Electronics: ↕	PG Drives ↕
Weight Capacity: ↕	180 KGS ↕
Warranty: ↕	2-year limited warranty on frame ↕
↕	1-year warranty on electronics ↕
↕	1-year warranty on drive motors ↕

Sample of marking plate: For example model: Wisking4020

MOBILITY SCOOTER
 Model No.: Wisking4020
 Maximum user's weight: 180kg/364.5Lbs.



Shanghai Wisking Electric Machine Co., Ltd.



EN 12184			
Clause	Requirement + Test	Result - Remark	Verdict
5	TYPE CLASSES		P
	Compact, manoeuvrable wheelchairs not necessarily capable of negotiating outdoor obstacles	Class A	N/A
	Wheelchairs sufficiently compact and manoeuvrable for some indoor environments and capable of negotiating some outdoor obstacles	Class B	P
	Wheelchairs, usually large in size, not necessarily indented for indoor use but capable of travelling over longer distances and negotiating outdoor obstacles.	Class C	N/A
6	GENERAL REQUIREMENTS		P
	Must conform to the requirements of EN 12182:1999 below		P
	Indented performance and technical documentation	Intended performance tested according to EN 12184: 2009 and described in the user manual.	P
	Aids that can be dismantled;	No dismantling for storage or transportation.	N/A
	Single use fasteners;	No such fasteners.	P
	Biocompatibility and toxicity;	Biocompatibility assessment provided.	P
	Contaminants and residues;	No substances can leak from the scooter.	N/A
	Infection and microbiological contamination;	Cleaning instruction in the user manual.	P
	Overflow, spillage, leakage and ingress of liquids;	No such liquids.	P
	Safety of moving parts;		P
	Prevention of traps for parts of human body;	No such traps.	P
	Folding and adjustment mechanism;		P
	Surface, corners, edge;	No burrs or sharp edges.	P
	Electronic programmable systems;		P
	Clinical evaluation;	It's not necessary because of this product.	P
	Ergonomics.	Considered.	P
	A risk analysis shall be carried out in accordance with EN ISO14971:2009.	Considered.	P
7	DESIGN REQUIREMENTS		P
7.1	Foot supports, lower leg supports and arm supports		P



EN 12184			
Clause	Requirement + Test	Result - Remark	Verdict
	The wheelchair shall be fitted with foot supports that have a means of positioning the user's feet at the required height, and prevent the user's feet from sliding backwards and shall meet the performance requirements specified in 8.2.	The scooter has a foot platform.	P
	Where fitted, leg supports and arm supports shall meet the performance requirements specified in 8.2.	Arm supports meet the requirements, no leg support.	P
7.2	Pneumatic tires		P
	All tyres have identical valve connections		P
	The tyres or the rims shall be marked with the maximum pressure in kPa or bar.	See page 3.	P
7.3	Fitting an anterior pelvic support		P
	The wheelchair shall have provision for an anterior pelvic support to be fitted. The manufacturer of the wheelchair shall have available as an option an anterior pelvic support which can be used with that provision.	Pelvic support is an available option	P
7.4	Wheelchairs for use as seats in motor vehicles		N/A
	<p>If the manufacturer specifies that the intended use of the wheelchair includes use by an adult as a seat in a motor vehicle, the wheelchair shall conform to the performance requirements of ISO 7176-19:2001.</p> <p>If the manufacturer specifies that the intended use of the wheelchair includes use as a seat in a motor vehicle by a child of mass greater than 22 kg, the wheelchair shall conform to the performance requirements of ISO 7176-19:2001 with the exception of the horizontal excursion limits and the selection of the Anthropomorphic Test Device (ATD). The horizontal excursion limits specified in Table 1 of ISO 10542-5:2004 and the ATD selection specified in Table A.I of ISO 10542-5:2004 shall apply.</p>	According to the user manual the scooter shall not be used as a seat in a motor vehicle.	N/A
7.5	Braking system		P
	The wheelchair shall be fitted with a braking system that meets the performance requirements specified in 8.4.	Electromagnetic braking system meets the performance requirements.	P
	If one or more brake levers are fitted to a wheelchair in the form used on bicycles and mopeds, the hand-grip width of such brake levers, measured 15 mm from the end of the brake lever, shall not be greater than 75 mm before a force is applied.	70 mm measured.	P
7.6	Freewheel device		P
	The wheelchair shall be fitted with a freewheel device that shall:		P



EN 12184			
Clause	Requirement + Test	Result - Remark	Verdict
	- be accessible and operable by the occupant or the assistant or both in accordance with the manufacturer's intended use,		P
	- be within the reach of the occupant, if it is intended to be operated by the occupant,		N/A
	- have maximum operating forces for engaging and disengaging that do not exceed those stated in Table 1,	Engaging 15 N, disengaging 15 N (maximum is 60 N)	P
	- be operable without detaching any parts,	No such part.	P
	- not depend on the battery power supplying the motor drive system,	No such device.	P
	- have two defined positions including clear indication of freewheel mode and drive mode,		P
	- prevent use of the wheelchair's drive system, if any part of the freewheel device is activated.	No such part.	P
7.7	Component mass		N/A
	If the wheelchair is intended to be dismantled for storage or transportation, any component that requires moving or handling and has a mass greater than 10 kg shall be provided with suitable handling devices (e.g. handles). The manufacturer shall provide information indicating the points where such components can be lifted and describe how it shall be handled during disassembling, lifting, carrying, and assembling to reduce risks to the person or persons moving or handling them.		N/A
7.8	Battery enclosures and containers		N/A
	Battery enclosures and containers shall: a) allow accessibility without the use of tools for inspection and service specified by the wheelchair manufacturer, b) provide protection so that it should not be possible for liquids dropping from above to enter into them and onto any cell or battery they contain, c) provide protection to stop any objects contacting the terminals of batteries and/or cells and the connections between them, to prevent a short circuit. Battery enclosures shall be ventilated at the side near to the highest point by an opening or openings which have a total area not less than 100 mm ² or as specified in 6.6.2 of EN 50272-3:2002 which ever is the greater.		N/A
	Battery containers shall d) be used where spillable batteries are fitted to the wheelchair, e) be resistant to corrosion caused by battery gases and acid.		N/A



EN 12184			
Clause	Requirement + Test	Result - Remark	Verdict

7.9	Operations intended to be carried out by the occupant and/ or assistant		P
	Wheelchairs shall be designed to facilitate ease of operation by the occupant and/or attendant as specified in the manufacturer's instructions and meet the performance requirements of 8.2.1, 8.5, 8.6.1, 8.7.1, 8.9, 8.12.1, 9.2 and 9.3. In addition, brake levers shall meet the applicable requirements of 8.4.1.		P
7.10	Controls intended for operation by the occupant		P
	Controls intended to be operated by the occupant while seated shall be within the occupant reach.	All controls on the dashboard and the circuit breaker under the seat are reachable.	P
7.11	Assistant control unit, push handles and handgrips		N/A
	When fitted, an assistant control unit, push handles and handgrips shall meet the performance requirements specified in 8.6.		N/A
7.12	Charging connector		P
	The wheelchair shall be fitted with a charging connector that meets the performance requirements specified in 8.7.		P

8	PERFORMANCE REQUIREMENTS		P
8.1	General		P
	Unless otherwise specified in this clause, the wheelchair shall be prepared as specified in ISO 7176-22:2000 for each test.		P
8.2	Foot supports, lower leg support assemblies and arm supports		P
8.2.1	Requirements		P
	Any swing away, movable or removable foot support assembly, leg support or arm support fitted on the wheelchair shall:		P
	a) incorporate a means to locate it securely in any intended operating position,	Locking mechanism for seat and arm support.	P
	b) be adjustable in increments not exceeding 25 mm,		P
	c) be accessible and operable by the occupant or an assistant or both in accordance with the manufacturers intended usage and within the occupant reach, and		P
	d) be operable without the use of tools.		P



EN 12184			
Clause	Requirement + Test	Result - Remark	Verdict
	When tested as specified below separate foot supports shall have a gap between them that - does not exceed 35 mm if intended for adults, - does not exceed 25 mm if intended for children, or - that is fitted with a means to prevent the occupant's feet from sliding into the gap.		N/A
	Test: a) Simultaneously apply a force F to the centroid of each foot support normal to the plane of the unloaded foot support. In cases where the foot support has no identifiable plane, apply the force within 5° of vertical. The force F is calculated from the following equation: $F = 0,125 \times m \times g$, where F is the force in Newtons applied to each foot support; m is the maximum occupant mass in kilograms specified by the manufacturer; g is 9.81 m/ss b) Apply the force for 5 s to 10 s. c) While the force is being applied measure the shortest distance between the foot supports. d) Record if the foot supports met the requirements.		N/A
8.3	Static, impact and fatigue strength		P
	The wheelchair shall conform to the requirements of ISO 7176-8:1998 with the exception that wheelchairs of type class A are not required to be tested as specified in 10.5 (drop test) of ISO 7176-8:1998.	Class B; See appended table 8.3.	P
	Arm supports and back supports shall conform to the static loading requirements of ISO 7176-8:1998 in all intended operating positions with the exception of the upward force on a push handle which shall be 880 N.	See appended table 8.3.	P
8.4	Braking system		P
8.4.1	General requirements		P
	a) The braking system shall		P
	- be accessible and operable by the occupant or an assistant or both in accordance with the manufacturer's intended use;		P
	- be within the occupant reach, if it is intended to be operated by the occupant;		P
	- have operating forces for engaging and disengaging as stated in Table 1.	Wig-wag is finger operated by max 3 N (max 5 N required)	P



EN 12184			
Clause	Requirement + Test	Result - Remark	Verdict
	- include a running brake, which operates independently of tire wear and tire inflation pressure and does not exceed the maximum stopping distance specified in Table 2 (e.g. manual brake control or control device);		P
	- include a running brake which when operated with the wheelchair in freewheel mode shall bring the wheelchair to a stop;		P
	- include an automatic brake, which operates independently of tire wear and tire inflation pressure and is operated by releasing the control device to achieve a zero speed command (e.g, spring loaded disc brake);		P
	include a parking brake which operates independently of tire wear and tire inflation pressure (e.g. drum brake in wheels, spring loaded disc) that shall:		P
	1) be operable when there is no power from the battery supplying the drive system,		P
	2) be operable when the wheelchair is in freewheel mode,		P
	3) meet the parking brake effectiveness requirement in Table 1,		P
	4) have provision for adjustment and/or replacement as specified by the manufacturer, if the parking brake is subject to wear,		P
	5) not have parts that protrude above the level of the unoccupied seat when the brake is engaged, if the wheelchair is fitted with arm supports that can be moved or removed to enable transfer,		P
	6) be operated either by hand or foot, and not exceed the brake lever operating forces of Table 1,		P
	7) not allow the loaded wheelchair to slide nor for its wheels to rotate its wheels when tested as specified in ISO 7176-3:2003 on the maximum slope established by Table 1 or on the maximum safe slope specified by the manufacturer if greater, when facing - up the slope and down the slope.	No sliding or rolling of the wheelchair at the slope of 15 degree up and down the slope.	P
	b) No brake mechanism shall have moved from the pre-set positions, no component or assembly of parts shall exhibit deformation, free play or loss of adjustment that adversely affects the function of the wheelchair when:		P
	- the wheelchair has been tested as specified in ISO 7176-8:1998 and	No deformation or other deterioration of the brake system after the tests.	P
	- the manual operated parking brake has been operated for 60 000 cycles.	No manually operated parking brake.	N/A
8.4.2	Tests	Test procedure applied according to ISO 7176-3:2003	P
8.4.2.1	Test for determination of brake lever operating forces	No manually operated brake lever	N/A
8.4.2.2	Test for the determination of the effectiveness of running brakes		P



EN 12184			
Clause	Requirement + Test	Result - Remark	Verdict
	The maximum stopping distances shall not exceed the distances specified in Table 2 of this standard	See appended table 8.4.2.	P
	The maximum value of deceleration shall not exceed the value specified in Table 2 of this standard	See appended table 8.4.2.	P
8.4.2.3	Test for the determination of the effectiveness of parking brakes	Test procedure applied on 12° slope.	P
8.4.2.4	Test for protrusion of parts of the parking brakes	No such parking brake	N/A
8.4.2.5	Test for fatigue strength of manually operated parking brakes	No manually operated parking brake	N/A
8.4.2.6	Test for the determination of the effectiveness of parking brakes after fatigue strength testing		P
8.5	Operating forces		P
	All controls shall have maximum operating forces for engaging and releasing as stated in Table 1.		P
	In addition to achieve the minimum performance of the system or device being operated, turning knobs operated by one hand shall have		N/A
	- the numerical value of the torque, expressed in Nm, for knobs greater than or equal to 25 mm in diameter shall not be greater than 0,05 times the numerical value of the diameter of the knob, expressed in mm, where the force is transmitted by friction and		N/A
	- the numerical value of the torque, expressed in Nm, for knobs less than 25 mm diameter shall not be greater than 0,025 times the numerical value of the diameter of knob, expressed in mm.		N/A
8.6	Assistant control unit, push handles and handgrips		N/A
8.6.1	When an assistant control unit is fitted, the unit shall be positioned behind the wheelchair's back support, between 900 mm and 1 200 mm from the floor to the centre of the operating means for the control input device (e.g. joystick handle). When an assistant control unit is fitted, a means to support the attendant's hand or hands used to operate the control device while the wheelchair is being driven shall be fitted.		N/A



EN 12184			
Clause	Requirement + Test	Result - Remark	Verdict
	<p>When push handles are fitted, no part of the wheelchair shall lie within a space to the rear of the wheelchair bounded by the following:</p> <ul style="list-style-type: none"> - a plane at 85° to the horizontal, that touches the rearmost points of the push handles; - two planes not less than 350 mm apart equidistant from a vertical plane parallel to the forward direction of travel that bisects the wheelchair; - the horizontal test plane. <p>When the wheelchair is fitted with steering and/or manoeuvring handgrips for assistant use, the handgrips shall be at least 75 mm in length and between 20 mm and 50 mm in diameter.</p> <p>When manoeuvring handgrips are fitted with controls that are intended to be used by being gripped by one hand, the handgrip width needed to grip them shall be no greater than 75 mm.</p>		N/A
8.7	Charging connector		P
	The charging connector shall be accessible and operable by the occupant and assistant within the occupant reach when operated as specified in the manufacturer's instructions.		P
8.8	Performance and driving characteristics		P
8.8.1	General		P
	The loaded wheelchair shall meet the driving performance requirements specified in Table 1 and Table 2 for the type class as specified in Clause 5.	Class B.	P
8.8.2	Ability to climb maximum safe slope		P
	<p>The wheelchair shall be capable of climbing at a minimum speed of 2 km/h:</p> <ul style="list-style-type: none"> - the applicable maximum safe slope specified in Table 1, or - the maximum safe slope specified by the manufacturer, whichever is greater. <p>The wheelchair passes the test, if it achieves or exceeds a speed of 2 km/h after traveling 5 m up the specified maximum safe slope without any visible lifting of any uphill wheel(s).</p>	Measured 10.1 km/h on safe slope of 10 degree.	P
8.8.3	Ground unevenness		P
	The wheelchair shall be capable of driving when any of the wheels of the wheelchair is raised to a height specified in Table 1 for ground unevenness.	100 mm passed.	P
8.8.4	Maximum downhill speed		P
	The wheelchair shall not exceed 125 % of its maximum speed on the horizontal, when driving down a gradient equivalent to its maximum safe slope.	Horizontal: 11.2 km/h, Downhill at 12°: 11.6km/h.	P
8.8.5	Dynamic stability		P



EN 12184			
Clause	Requirement + Test	Result - Remark	Verdict
	The dynamic response score of the wheelchair shall be 2 or 3 as specified in Table A.1 of ISO 7176-2:2001 when tested on the slopes specified in Table 1 of this European Standard for the type class of wheelchair and at the maximum safe slope as specified by the manufacturer.	6° slope for Class B.	P
8.8.6	Obstacle climbing		P
	The wheelchair shall be capable of climbing and descending obstacles of the height specified in Table 1 for the type class of the wheelchair without any part of the wheelchair other than wheels or a kerb climbing device contacting the obstacle or the test plane.	Required: 100 mm, Climbing ability: 100 mm	P
8.8.7	Static stability		P
	The wheelchair shall meet or exceed the minimum requirements for static stability as specified in Table 1 for the type class of the wheelchair. Test the loaded wheelchair as specified in ISO 7176-1:1999 to determine whether the static stability meets or exceeds the angles in Table 1 for the type class of the wheelchair.	Required 9° for Class B scooter, Measured minimum 15.4°.	P
8.8.8	Maximum speed		P
	The maximum speed of the wheelchair when traveling forwards and traveling in reverse on the horizontal shall not exceed the maximum speed requirements specified in Table 1 for the type class of the wheelchair.	Forwards 11.2 km/h < 15km/h Reverse 4.0 km/h < 5 km/h	P
8.8.9	Distance range		P
	The theoretical continuous driving distance range for the wheelchair shall not be less than the requirement specified in Table 1 for the type class of the wheelchair.	Required: 25 km, Measured: 25.7 km.	P
8.9	Surface temperature		P
	Surfaces of the wheelchair that can come into direct contact with the occupant's skin and/or assistant's skin during normal use and that are within occupant reach shall not exceed 41° C when tested as specified in EN 12182:1999. If an ambient temperature is not specified, test at an ambient temperature of 20° C +/- 2° C.	The temperatures of all parts, which can come into direct skin contact during normal use, are equal to the ambient temperature.	P
8.10	Resistance to ignition		P
8.10.1	Upholstered composite parts		P



EN 12184			
Clause	Requirement + Test	Result - Remark	Verdict
	For upholstered parts which are composites of cover and filling, with or without a support base or interliner, the complete composite shall be tested by the methods specified in EN 1021-1:2006 and EN 1021-2:2006. Progressive smouldering ignition and flaming ignition as defined in these European Standards shall not occur.	Material of the scooter seat was approved.	P
8.10.2	Foam materials		N/A
	For foam materials which form all or part of a seat, back support, postural support, arm support or leg support which consist of foam material with or without an integral skin the material of each part shall be tested with the source applied centrally to the material face that contacts the user by the methods specified in EN 1021-1:2006 and EN 1021-2:2006. Progressive smouldering ignition and flaming ignition as defined in these European Standards shall not occur.	No such material used.	N/A
8.10.3	Other parts		N/A
	For sling seats, sling backs, belts, restraint harnesses, foot supports and clothing guards, the material of each item shall be tested with the source applied centrally to the material face that contacts the occupant by the methods specified in EN 1021- 1:2006 and EN 1021-2:2006. Progressive smouldering ignition and flaming ignition as defined in these European Standards shall not occur.	No such seat belt.	N/A
8.11	Climatic test		P
	The wheelchair shall conform to the requirements of ISO 7176-9:2001. The spray water test in clause 14.2.4 of EN 60529:1991 shall also be carried out.	Test was performed successful.	P
8.12	Seating adjustment for tilt and recline systems		P
	If the manufacturer specifies that the seating can be adjusted by an assistant or the occupant or both while the occupant is seated, the assistant and/or the occupant shall not have to lift a mass (e.g. the combined mass of the occupant and the seating) which presents a moving and handling safety hazard to the assistant and /or the occupant. Controls for seating adjustments intended to be operated by the occupant shall be accessible to the occupant from all seating positions.	The seat is only to adjust when the scooter is not occupied.	N/A
9	ELECTRICAL REQUIREMENTS		P
9.1	General requirements		P



EN 12184			
Clause	Requirement + Test	Result - Remark	Verdict
	The wheelchair shall conform to the requirements of ISO 7176-14:2008 and ISO 7176-21:2003. In addition, wheelchairs that include an on board battery charger shall conform to the applicable electrical requirements of EN 60601-1:2006 and EN 61000-3-2:2006 for EMC.	External battery charger used. Company: PowerFirst Technology Company Limited; Model: PF2408LP; Input: 180-240Vac, 50Hz, 2.0A; Output: 24Vdc/8A; Apporved by TUV CE, TUV GS.	P
9.2	Requirement for controller on/off switch		P
	Provision shall be made for the occupant and/or assistant to switch the wheelchair on and off. Switches intended to be operated by the occupant shall be within the occupant reach area. Switches intended to be operated by an assistant shall be attached to the assistant control unit positioned as specified in 8.6.1. If the wheelchair is switched off while driving on the horizontal, it shall come to a stop within the maximum stopping distances specified in Table 2.	Key switch on the tiller. Measured 0.7 m at 11.2 km/h.	P
9.3	Requirement for power indicator		P
	The wheelchair shall be fitted with a device to indicate to the occupant and/or assistant that power is switched on. The colour of this indication shall conform to EN 60601-1:2006.	Yellow/Green LED.	P
9.4	Requirement for circuit protection		P
	Circuits connected to batteries on the wheelchair shall be protected against excessive current. The driving, braking and steering functions shall not be affected by the operation of the means of protection of any other circuit. Lights, direction indicators and hazard warning flasher functions shall not be affected by the operation of the means of protection of any other circuit.		P
9.5	Requirements for battery chargers		P
	Battery chargers for wheelchairs shall conform to the requirements of ISO 7176-14:1997 that apply to battery chargers, together with the following provisions:		P
	a) battery chargers shall indicate when charging is in progress and when charging is complete;	See the battery monitor on the panel	P
	b) battery chargers shall have the capability of charging batteries discharged to 70 % of their nominal voltage;		P



EN 12184			
Clause	Requirement + Test	Result - Remark	Verdict
	c) battery chargers shall operate without the need for intervention or supervision apart from connecting and turning on at the start of charging and turning off and disconnecting at the end of charging;	No intervention necessary apart from connecting and disconnecting.	P
	d) carry-on and on-board battery chargers shall meet the environmental protection requirements of IPX4 when tested in accordance with EN 60529:1991 and meet the Class II Test Voltage requirements of EN 60335-1:2002 concluding the test.	External charger.	N/A
9.6	Charge level indicator		P
	The wheelchair shall be equipped with a charge level indicator.	LED indicator on the dashboard display.	P

10	REQUIREMENTS FOR INFORMATION SUPPLIED BY THE MANUFACTURER		P
10.1	General		P
	Each wheelchair shall be provided with documentation and labeling that conform to the requirements in EN 12182:1999 and ISO 7176-15:1996. In addition the manufacturer shall provide the documentation in three separate sections: pre-sale, user and service information as specified in 10.2, 10.3 and 10.4. These may be provided as separate printed documents or in other forms of media to meet the needs of individual occupants or their assistants.		P
10.2	Pre-sale information		P
	In addition to the requirements of 10.1, pre-sale information shall include the following:		P
	a) information on how to obtain the user information in a format appropriate for use by visually impaired people;	The product is not to use by visually impaired people.	N/A
	b) description of the intended occupant of the wheelchair (as a minimum this will include user mass plus any specific requirements for functional capability, visual ability and cognisance to operate the wheelchair safely in its intended environment);	Stated in the user manual.	P
	c) description of the intended use and the intended environment;	Ditto.	P
	d) the wheelchair type class: A, B or C;	Class B	P
	e) the overall dimensions (width, length and height) in mm and mass in kg when operational and if applicable when folded or dismantled;	Stated in the user manual.	P
	f) reversing width, expressed in mm;	Ditto.	P
	g) the maximum safe slope in degrees;	Ditto.	P



EN 12184			
Clause	Requirement + Test	Result - Remark	Verdict
	h) maximum height of kerb which the wheelchair can descend safely in mm;	Ditto.	P
	i) information concerning whether the removal of parts or accessories intended by the manufacturer to be removed without the use of tools will have adverse or beneficial effects on the wheelchair;	Ditto.	P
	j) standard options that are available for the wheelchair;	Ditto.	P
	k) type of tyres that can be used on the wheelchair;	Ditto.	P
	l) if a programmable controller is fitted, information on method of programming, who should carry out the programming and the effect it can have on driving performance;	Ditto.	P
	m) operator control adjustments;	Ditto.	P
	n) theoretical continuous driving distance range in km that the wheelchair can travel under its own power on the horizontal when tested in accordance with ISO 7176-4:2008, with the addition of a note explaining that the distance will be reduced if the wheelchair is used frequently on slopes, rough ground or to climb kerbs etc.;	Ditto.	P
	o) whether and how the wheelchair can be folded or dismantled to assist in storage or transport;	Ditto.	P
	p) if the wheelchair can be dismantled or has any removable parts; the mass of the heaviest part in kg;	Ditto.	P
	q) instruction regarding transport of the wheelchair when it is unoccupied (e.g. in a car or aeroplane);	Ditto.	P
	r) information on whether or not the wheelchair is intended to be used as a seat in a motor vehicle;	Ditto.	P
	s) if the manufacturer specified that the wheelchair is intended for use as a seat in a motor vehicle, the method of attaching wheelchair tiedown and occupant restraints and recommendations about suitable tiedown and restraint systems.		N/A
10.3	User information		P
	User information shall be provided by the manufacturer with each wheelchair. Further copies shall also be available for any subsequent user of the wheelchair. User information shall contain all pre-sale information and the following:	Refer to 10.2.	P
	a) unique identification number of the wheelchair and information on the location of the unique identification number on the wheelchair;	Stated in the user manual.	P
	b) the intended operator (occupant, assistant or both);	Ditto.	P



EN 12184			
Clause	Requirement + Test	Result - Remark	Verdict
	c) any adjustment or settings required before the wheelchair can be used and warnings of how adjustments or settings affect stability;	Ditto.	P
	d) where applicable, information on any adjustments that can be made and who is competent to carry out these adjustments;	Ditto.	P
	e) instructions on operation of all controls, including brakes;	Ditto.	P
	f) instruction on how to engage and disengage the drive system;	Ditto.	P
	g) the wheelchair manufacturer's recommended tyre pressure(s) in kPa or bar;	Ditto.	P
	h) instructions for dealing with tyre punctures, where pneumatic tyres are fitted;	Ditto.	P
	i) the battery type and nominal voltage;	Ditto.	P
	j) instructions for battery maintenance;	Ditto.	N/A
	k) instructions for operating the battery charger, including warnings regarding any potential safety hazards (e.g. a possibility of gas accumulating in the charging area);	Ditto.	P
	l) instructions on dismantling and re-assembly of the wheelchair or any removable parts:	Ditto.	P
	m) the masses of parts of the wheelchair that are expected to be handled during dismantling, reassembly, or carrying; expressed in kilograms	Ditto.	P
	n) the positions of points where the component parts can be gripped for safe moving and handling and/or a method for handling during dismantling, assembly or carrying;	Ditto.	P
	o) a warning that surface temperatures can increase when exposed to external sources of heat (e.g. sunlight);	Ditto.	P
	p) a warning that the wheelchair might disturb the operation of devices in its environment that emit electromagnetic fields (e.g. alarm systems of shops, automatic doors etc.);	Ditto.	P
	q) a warning that the driving performance of the wheelchair can be influenced by electromagnetic fields (e.g. those emitted by portable telephones, electricity generators or high power sources);	Ditto.	P
	r) a warning if driving characteristics can be adjusted outside the limits specified in Table 1 and Table 2;		N/A
	s) a warning for trapping hazards (e.g. pinch points);	Ditto.	P
	t) the level of resistance to ignition of materials and assemblies;	Ditto.	P



EN 12184			
Clause	Requirement + Test	Result - Remark	Verdict
	u) information on the recycling of used batteries and other parts of the wheelchair;	Ditto.	P
	v) a warning if the adjustments of seating or wheel positions can be set outside safe limits;		N/A
	w) the expected service life of the wheelchair.	Ditto.	P
10.4	Service information		P
	The service information shall contain all the pre-sale, user information and instructions necessary for the maintenance, adjustment and repair of the wheelchair and for the replacement of parts.		P
10.5	Labels		P
	In addition to the requirements of 10.1, the manufacturer shall apply permanent labels for the following:		P
	a) devices for disengagement of the drive system, showing engaged and disengaged positions, including a warning that the drive system should be re-engaged before an occupant is left unattended or attempts to operate the wheelchair;		P
	b) for wheelchairs where the intended use includes use as a seat in a motor vehicle, the position of attachment points for wheelchair tie-down and occupant restraint systems (WTORS);		N/A
	c) the year of production for the product;	See the label.	P
	d) for battery chargers that are not on board chargers, information and connection details specified in Clause 9 of ISO 7176-14:1997.	According to the user manual only the from the scooter manufacturer provided charger is to use. All necessary Information is stated on the battery charger.	P
	e) for wheelchairs not intended to be used as a seat in a motor vehicle a warning label that it is not intended to be used as a seat in a motor vehicle.	Sticker on the scooter.	P
	f) for class A wheelchairs for use indoors only a warning that it should only be used indoors.	Class B.	N/A
11	Test report		P



EN 12184			
Clause	Requirement + Test	Result - Remark	Verdict
	<p>The test report shall contain the following information:</p> <ul style="list-style-type: none">a) a unique report number;b) the name and address of the testing institution;c) the date of issue of the test report;d) a reference to this European Standard, i.e. EN 12184:2009;e) the name and address of the manufacturer of the wheelchair;f) a description of the sample including the manufacturer's or vendor's trade mark, model or type, serial number and any variations or accessories fitted;g) manufacturer, type and model of controller and motors and the capacity of the batteries fitted to the wheelchair during the tests;h) the source of the sample;i) details of the set-up of the wheelchair as specified in ISO 7176-22:2000, including details of how it is equipped and adjustments;j) the ambient temperature at which each test was carried out;k) the size of the dummy used or, if a person is used, the mass of the occupant and weights;l) where the controller is programmable, the settings used while testing;m) photograph of the sample equipped as during the test;n) results of the tests;o) statement of whether or not the tested sample met all of the applicable requirements of this European Standard and list all the failed requirements.	All required information stated in the test report.	P



EN 12184			
Clause	Requirement + Test	Result - Remark	Verdict
Table 8.3	Static, impact and fatigue strength		Verdict
	Test Items	ISO 7176-8 cl.	
Static Test:			
	1.Armrests (Resistance to downward force)	8.4 Test load: 770 N	P
	2.Footrest (Resistance to downward force)	8.5 Test load: 1000 N	P
	3.Tipping lever	8.6 Test load: N	N/A
	4.Handgrips	8.7 Test load: N	N/A
	5.Armrest (Resistance to upward force)	8.8 Test load: N	N/A
	6.Footrest (Resistance to upward force)	8.9 Side Test load: N Center Test load: N	N/A
	7.Push handle (Resistance to upward force)	8.10 Side Test load: N Center Test load: N	N/A
Impact Test:			
	8.Backrest (impact)	9.3 Test pendulum at: 30±2°	P
	9.Hand rim (impact)	9.4 Test pendulum at	N/A
	10.Castors (impact)	9.5 Test pendulum at	N/A
	11-1.Footrest (lateral impact)	9.6.3 Test pendulum at	N/A
	11-2.Footrest (longitudinal impact)	9.6.4 Test pendulum at	N/A
	12-1.Front structure (frontal impact)	9.7.2 Test pendulum at 80°	P
	12-2.Front structure (offset impact)x	9.7.3 Test pendulum at 80°	P
Fatigue Test:			
	13.Two-drum test	10.5 Test equipment 200000 rev.	P
	14.Drop test	10.5 Test equipment 6666 drops freely 50mm ± 5mm.	P
Remark: Test the wheelchair in accordance with ISO 7176-8:1998.			

Table 8.4.2.	Braking System			P
Test plane inclination	Direction of travel	Min brake distance (m) At km/h,		
		Normal operation	Reverse command	Emergency power off
Horizontal	Forwards	0.7	0.7	0.7
	Reverse	0.4	0.4	0.4
10 degrees	Forwards	1.6	1.6	1.6
	Reverse	1.1	1.1	1.1
Remark: The test accordance with ISO 7176-3.				

EN 12184			
Clause	Requirement + Test	Result - Remark	Verdict

Appendix 1
Photo documentation



Fig. 1



Fig. 2

EN 12184			
Clause	Requirement + Test	Result - Remark	Verdict



Fig. 3

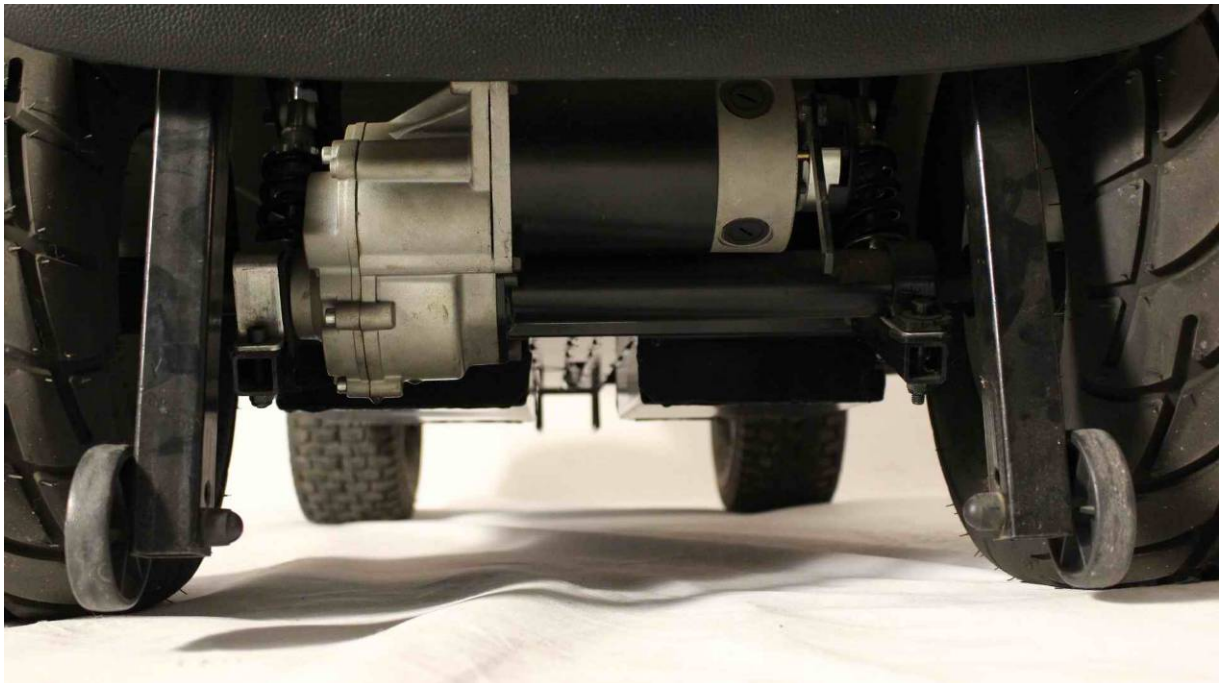

Fig. 4

EN 12184			
Clause	Requirement + Test	Result - Remark	Verdict



Fig. 5

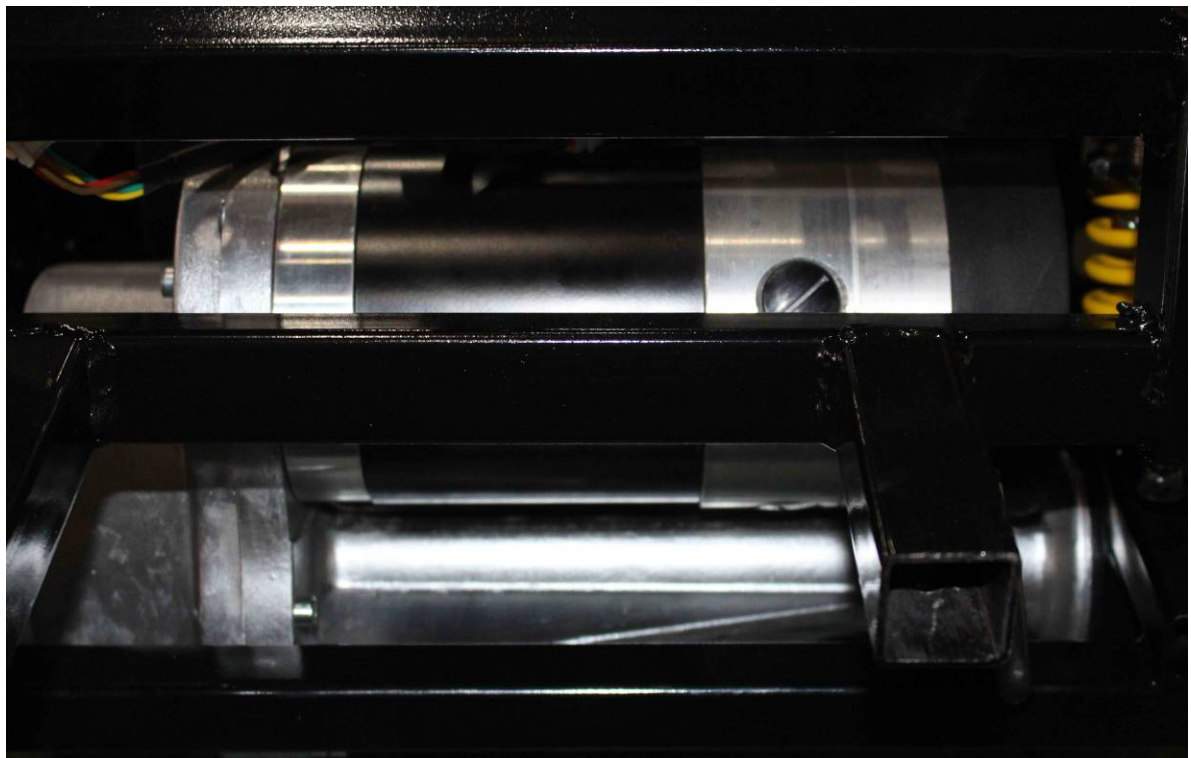

Fig. 6

EN 12184			
Clause	Requirement + Test	Result - Remark	Verdict

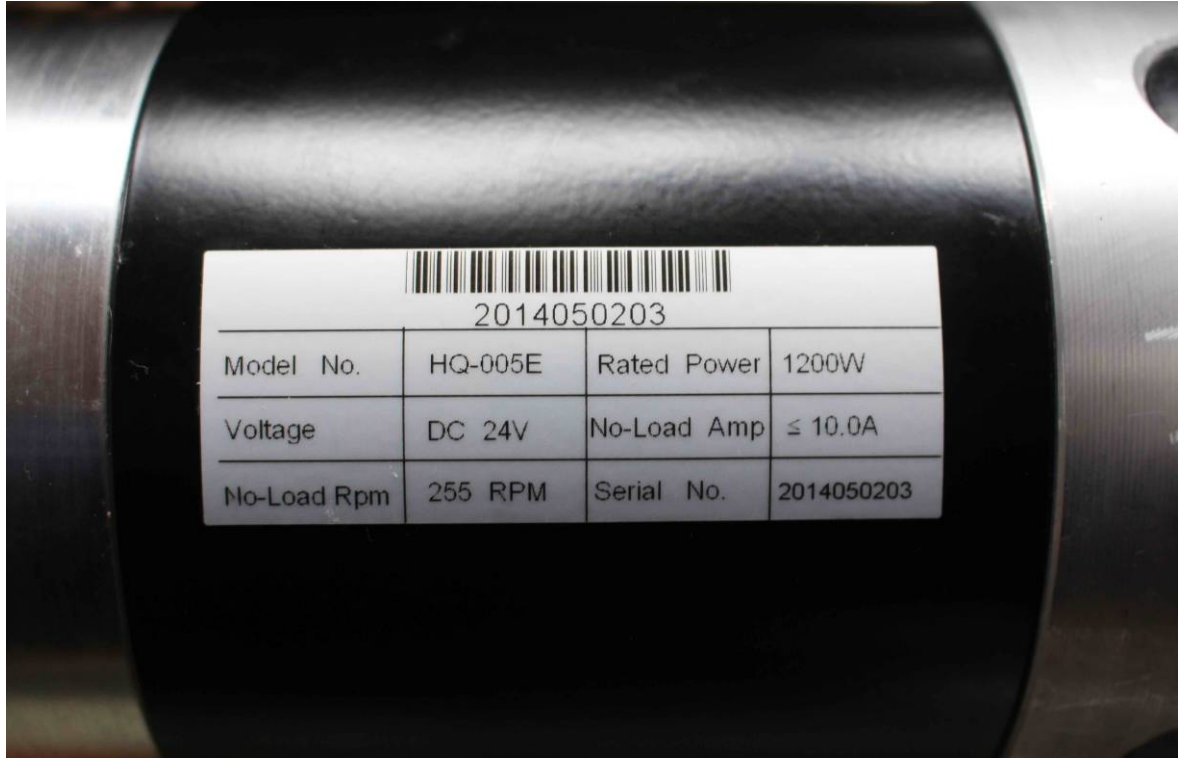

Fig. 7



Fig. 8

EN 12184			
Clause	Requirement + Test	Result - Remark	Verdict



Fig. 9



Fig. 10

EN 12184			
Clause	Requirement + Test	Result - Remark	Verdict



Fig. 11



Fig. 12

*****END OF REPORT*****