

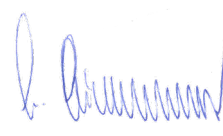

Report No.: 713293481-3

<b>TEST REPORT</b>			
<b>Standard EN 12183:2022</b>			
<b>TUV SUD Test Report for manual wheelchairs</b>			
Report No.:	713293481-3		
Date of issue:	2023-08-30		
Project handler:	Jens Meyer		
Testing laboratory:	TÜV SÜD Product Service GmbH		
Address:	Masurenweg 1-3, DE-30163 Hanover		
Testing location:	as above		
Client:	Sunrise Medical GmbH		
Client number:	5010253552		
Address:	Kahlbachring 2-4, DE-69254 Malsch		
Contact person:	Gerd Weis		
Standard:	This TUV SUD test report form is based on the following requirements: EN 121832: 2022		
TRF number and revision:	TRF EN 12183: 2022 rev. 0:2022		
eDoc_ID:	N/A		
TRF originated by:	TUV SUD Product Service, Mr. Jens Meyer		
Copyright blank test report:	<p>This test report is based on the content of the standard (see above). The test report considered selected clauses of the a.m. standard(s) and experience gained with product testing. It was prepared by TUV SUD Product Service.</p> <p>TUV SUD Group takes no responsibility for and will not assume liability for damages resulting from the reader's interpretation of the reproduced material due to its placement and context.</p>		
General disclaimer:	<p>This test report may only be quoted in full. Any use for advertising purposes must be granted in writing. This report is the result of a single examination of the object in question and is not generally applicable evaluation of the quality of other products in regular production.</p>		
Scheme:	<input type="checkbox"/> TUV Mark <input checked="" type="checkbox"/> without certification <input type="checkbox"/> AoC/CoC for EU-Directive / EU-Regulation: <input type="checkbox"/> GS Mark <input type="checkbox"/> NRTL Mark <input type="checkbox"/> other:		
Non-standard test method:	<input checked="" type="checkbox"/> No <input type="checkbox"/> Yes, see details under <i>Summary of testing</i>		
National deviations:	N/A		
Number of pages (Report):	67		
Number of pages (Attachments):	N/A		
Compiled by:	Jens Meyer	Approved by:	Michael Steinmann
(+ signature)		(+ signature)	
	SIGN-ID 827356 30.08.2023		SIGN-ID 827431 30.08.2023

Test Report EN 12183:2022



Report No.: 713293481-3

Test sample:	HAN-707965-1, -2, HAN-707966-1, -2
Type of test object:	Manual wheelchair
Trademark:	
Model and/ or type reference:	QS5 X ff / QS5 X sa
Rating(s):	See copy of marking plate
Manufacturer:	Sunrise Medical GmbH
Manufacturer number:	1300036070
Address:	Kahlbachring 2-4, DE-69254 Malsch
<b>Name and address of factory(ies)</b> Sunrise Medical GmbH Kahlbachring 2-4 DE-69254 Malsch	
Sub-contractors / tests (clause):	N/A
Name:	N/A
Order description:	<input checked="" type="checkbox"/> Complete test according to TRF
	<input type="checkbox"/> Partial test according to manufacturer's specifications
	<input type="checkbox"/> Preliminary test
	<input type="checkbox"/> Spot check
	<input type="checkbox"/> Others:
Date of order:	2023-01-25
Date of receipt of test item:	2023-02-07 (test samples) 2023-01-20, 2023-01-23, 2023-04-12, 2023-07-20, 2023-07-25, (technical documentation)
Date(s) of performance of test:	2023-07-03 to 2023-08-30
<b>Test item particulars:</b> - QS5 X sa, Seat width 340 mm and 540 mm; with height-adjustable and removable footrests - QS5 X ff, Seat width 340 mm and 540 mm; with height-adjustable and fixed footplate	
<b>Purpose of the product</b> (description of intended use): Wheeled personal mobility device incorporating a seating support system for a disabled occupant that is manually propelled by the occupant and/or an assistant whilst the occupant is seated.	

Report No.: 713293481-3

**Characteristic data** (not shown on the marking plate):

total length incl. footrests:	750 - 1113 mm
width:	530 - 745 mm
height:	725 - 945 mm
seat width:	340 - 540 mm
seat depth:	340 - 500 mm
seat height (front side):	360 - 540 mm
backrest height:	250 - 500 mm
seat plane angle:	84°
backrest angle:	80° - 105°
max. user weight:	140 kg
brake system:	knee lever brake (standard brake)
back wheels:	24 x 1" air filled/ puncture proof yes quick release
front wheels:	Ø 140 x 40 mm Ø 100 x 35 mm puncture proof yes rigid
frame material:	aluminum
armrest:	not available
legrest:	- height-adjustable and removable footrests (sa) - footplate, height adjustable (ff)
anti tip device	adjustable

**Attachments:**

N/A

**If additional information is necessary, please provide**

Ambient temperature range during testing: 21°C to 24°C

**Copy of marking plate:**



Test Report EN 12183:2022

Report No.: 713293481-3

**Pictures of the product:**



Report No.: 713293481-3



Test Report EN 12183:2022



Report No.: 713293481-3

**Summary of testing:**

The product fulfils the requirments of EN 12183:2022

deviation(s) found

no deviations found

*The decision rule "Binary statement with guard band – guard band length = 95 % extended measurement uncertainty" according to ILAC-G8:09/2019 was applied.*

**Additional information on non-standard test method(s)**

Sub clause: N/A

Page: N/A

Rational: N/A

**Possible test case verdicts:**

test case does not apply to the test object: N/A (not applicable / not included in the order)

test object does meet the requirement: P (Pass)

test object does not meet the requirement: F (Fail)

*General remarks:*

*"(see remark #)" refers to a remark appended to the report.*

*"(see appended table)" refers to a table appended to the report.*

*Throughout this report a **comma** is used as the decimal separator.*

*The test results presented in this report relate only to the object tested.*

*This report shall not be reproduced except in full without the written approval of the testing laboratory.*

Clause	Requirement + Test	Result – Remark	Verdict
1.	<p><b>Scope</b></p> <p>This document specifies requirements and test methods for manual wheelchairs intended to carry one person of mass not less than 25 kg and not greater than 250 kg, including</p> <ul style="list-style-type: none"> <li>- stand-up manual wheelchairs, and</li> <li>- manual wheelchairs whose intended use includes showering and/or toileting.</li> </ul> <p>This document does not apply to custom-made manual wheelchairs, manual wheelchairs intended for use in sports, or manual wheelchairs intended only for showering and/or toileting.</p> <p>This document also specifies requirements and test methods for manual wheelchairs with electrically powered ancillary equipment.</p>		
2.	<b>Normative references</b>		
3.	<b>Terms and definitions</b>		
4.	<b>Test apparatus</b>		
5.	<b>General requirements</b>		
5.1	<b>Risk management</b>		
	<p>A risk management process shall be performed in accordance with EN ISO 14971:2019<sup>1</sup>.</p> <p>For conformity with this document, all elements of the risk management process specified in EN ISO 14971:2019<sup>1</sup> shall be applied.</p>	<p>Risk analysis, dated 2023-02-13 available.</p>	P
	<p>Except:</p> <ul style="list-style-type: none"> <li>- the planning for, and execution of, production and post-production monitoring (EN ISO 14971:2019<sup>1</sup>, 4.1 fourth indent, 4.4 item g), and clause 10); and periodic reviews of the suitability of the risk management process (EN ISO 14971:2019<sup>1</sup>, 4.2 third paragraph).</li> </ul>		

Clause	Requirement + Test	Result – Remark	Verdict
<b>5.2</b>	<b>Intended performance and technical documentation</b>		
	a) The wheelchair shall have sufficient strength and durability to sustain all loads expected during intended use. This shall be confirmed by using, where appropriate, references to relevant clinical and scientific literature, strength and/or durability calculations, appropriate test standards and their test results, in addition to the requirements given in this document.		P
	b) The intended performance of the wheelchair, including, where appropriate, strength, durability and tipping stability, shall be described in technical documentation which sets out its functional characteristics, its application(s) and conditions of use.		P
	c) The technical documentation shall include, where appropriate, references to relevant clinical and scientific literature, any strength and/or life calculations, appropriate test standards and their test results.		P
<b>5.3</b>	<b>Clinical evaluation and investigation</b>		
	A clinical evaluation shall be conducted for the wheelchair.	Clinical evaluation, dated 2022-04-25 available.	P
	<p>If, as part of the product conformity assessment, the clinical evaluation requires a clinical investigation, the clinical investigation shall conform to the requirements of EN ISO 14155:2020.</p> <p>A clinical evaluation shall always be conducted before performing a clinical investigation.</p> <p>NOTE Guidance for clinical evaluation is given in MEDDEV 2.7/1 [19].</p>		N/A

Clause	Requirement + Test	Result – Remark	Verdict
<b>5.4</b>	<b>Wheelchairs that can be dismantled</b>		
	If it is intended that the wheelchair can be dismantled for storage or transportation, it shall not be possible to reassemble the wheelchair in a manner that presents a hazard.		P
<b>5.5</b>	<b>Single-use fasteners</b>		
	If it is intended that the wheelchair can be dismantled for storage or transportation, the fasteners which are loosened or removed to allow this dismantling shall not be single-use fasteners. EXAMPLE: Single-use fasteners include wood screws and self-tapping screws.		N/A
<b>5.6</b>	<b>Biocompatibility and toxicity</b>		
	Materials which come into contact with the human body shall be evaluated for biocompatibility in accordance with EN ISO 10993-1:2020 as part of the risk management process (see 5.1). The evaluation shall take into account the intended use, including, where appropriate, contact with the occupant, an assistant, those involved in care of the occupant, and those involved in transportation and storage of the wheelchair.	Test material: Brake handle, black Test standard: EN ISO 10993-5 Test lab: HYGCEN Germany GmbH Test report no.: SN 31481; dated 2021-02-16  Test material: Push handle, black Test standard: EN ISO 10993-5 Test lab: HYGCEN Germany GmbH Test report no.: SN 28004; dated 2019-08-05  Test material: Backrest upholstery, black) Test standard: ISO 10993-5 Test lab: Sanitation & Environment Technology Institute, Soochow University, China Test report no.: SDWH-M202205990-1 (E), dated 2022-08-02  Test material: Seat upholstery, black) Test standard: EN ISO 10993-5 Test lab: Zwisler smart lab solutions Test report no.: 2206.1056, dated 2022-06-27	P

Clause	Requirement + Test	Result – Remark	Verdict
	<p>Wheelchairs shall be designed and manufactured to minimize the risks posed by substances leaking from them.</p> <p>Special attention shall be given to substances which are carcinogenic, mutagenic or toxic to reproduction and other substances of very high concern (SVHCs).</p> <p>The evaluation should follow the guidance given in Annex E.</p> <p>NOTE: See Annex E for additional guidance.</p>	Reach declarations available.	P
<b>5.7</b>	<b>Contaminants and residues</b>		
<b>5.7.1</b>	<b>General</b>		
	The requirements given in 5.7.2 apply to substances which are an integral part of the wheelchair or are necessary for its function, such as oil and grease. The requirements do not apply to body fluids which the wheelchair is intended to collect (e.g. as a stoma-care product).		
<b>5.7.2</b>	<b>Substances which can leak in intended use or in a fault condition</b>		
	Where a substance can leak from the wheelchair in intended use or in a fault condition:		
	a) the substance shall be assessed for biocompatibility in accordance with EN ISO 10993-1:2020 as part of the risk management process, and the assessment shall consider intended use, including, where appropriate, contact with the occupant, an assistant, those involved in care of the occupant, and those involved in transportation and storage of the wheelchair; or		N/A
	<p>b) the wheelchair shall have means of protection that minimizes the possibility of the substance becoming a biological hazard.</p> <p>NOTE: Substances that can leak include lubricants and hydraulic fluids.</p> <p>EXAMPLE: A method of protection from a hazardous substance is to place batteries in a container made from acid resistant material.</p>		N/A

Clause	Requirement + Test	Result – Remark	Verdict
<b>5.8</b>	<b>Infection and microbiological contamination</b>		
<b>5.8.1</b>	<b>Cleaning and disinfection</b>		
	If any parts of the wheelchair are intended to be cleaned, the method and suitable materials for cleaning shall be described in the instructions for use.		P
	If any parts of the wheelchair are intended to be disinfected, the method and suitable materials for disinfection shall be described in the instructions for use. NOTE For guidance, see B.2.5.		P
	If any parts of the wheelchair are intended to be cleaned by automatic washing systems or hand-held jet stream or steam washing, the details of the procedure, such as temperature, pressure, flow and pH value of cleaning/rinsing solution, shall be described in the instructions for use. Where practicable, the wheelchair shall be labelled with appropriate symbols to represent the method of cleaning.		N/A
<b>5.8.2</b>	<b>Animal tissue</b>		
	Where the wheelchair has been manufactured utilizing tissues of animal origin or their derivatives, the process specified in EN ISO 22442-1:2020 shall be followed as part of the risk management process (see 5.1). NOTE For guidance, see B.2.11.		N/A
<b>5.9</b>	<b>Overflow, spillage, leakage, and ingress of liquids</b>		
<b>5.9.1</b>	<b>Overflow</b>		

Clause	Requirement + Test	Result – Remark	Verdict
<b>5.9.1.1</b>	<b>Requirements</b>		
	If the wheelchair incorporates a reservoir or liquid storage chamber that can be overfilled or can overflow in intended use, liquid overflowing from the reservoir or chamber shall not wet electrical insulation or live parts which are liable to be adversely affected by such a liquid, nor shall a hazard be created. Unless indicated by a marking or by the instructions for use, no hazard shall be created if the wheelchair is tilted through an angle 15° greater than the maximum inclination that can occur during intended use.		N/A
<b>5.9.1.2</b>	<b>Test method</b>		
	Fill the reservoir to the maximum level specified by the manufacturer and, if possible, add further liquid equal to 15 <sup>+1</sup> <sub>0</sub> % of the capacity of the reservoir or until the reservoir is full, whichever is the lesser quantity. Tilt the wheelchair through an angle of $(\alpha + 15)^{+1}_0$ ° to the horizontal in each direction, where $\alpha$ is the maximum slope for use of parking brakes. If necessary, refill the reservoir between tests.		
<b>5.9.2</b>	<b>Spillage</b>		
<b>5.9.2.1</b>	<b>Requirements</b>		
	Wheelchairs requiring the handling of liquids in intended use shall be so constructed that spillage does not wet parts that creates a hazard.		N/A
<b>5.9.2.2</b>	<b>Test method</b>		
	Position the wheelchair on the horizontal test plan. Pour 200 ml <sup>+5</sup> <sub>0</sub> of water steadily on an arbitrary point on the seat. After the test, the wheelchair shall function as specified by the manufacturer.		
<b>5.9.3</b>	<b>Leakage</b>		
	Wheelchairs shall be so constructed that liquid which can escape in single fault condition does not create a hazard.		N/A

Clause	Requirement + Test	Result – Remark	Verdict
<b>5.9.4</b>	<b>Ingress of liquids</b>		
<b>5.9.4.1</b>	<b>Requirements</b>		
	If liquid can enter an enclosure unintentionally, either there shall be a means for the liquid to escape from the enclosure, or the liquid shall not create a hazard.		P
	Hazards that can be caused by the ingress of liquids shall be addressed in the risk management process (see 5.1). NOTE See B.2.12.		N/A
<b>5.9.4.2</b>	<b>Test method</b>		
	Test whether the liquid can escape from an enclosure by adding liquid and then tilting the wheelchair 10° in each direction. If any liquid remains in the enclosure, test the wheelchair to determine whether it is still functional, and determine whether the liquid can create a hazard.		
<b>5.10</b>	<b>Safety of moving parts</b>		
<b>5.10.1</b>	<b>Squeezing</b>		
	Unless the intended purpose of part of the wheelchair is to grip, cut, squeeze or provide a similar function, or if the intended use cannot be achieved without a risk of squeezing:		
	a) any moving parts that constitute a hazard shall be provided with guards that cannot be removed without the use of a tool; or		N/A
	b) the gap between exposed parts of the wheelchair that move relative to each other shall be maintained throughout the range of movement at less than the relevant minimum value or more than the relevant maximum value specified in Table 1; or		

Clause	Requirement + Test	Result – Remark	Verdict																	
	Table 1 - Safe distances between moving parts																			
	<table border="1"> <thead> <tr> <th rowspan="2">To avoid</th> <th colspan="2">Safe distances</th> </tr> <tr> <th>for adults <input checked="" type="checkbox"/> applicable</th> <th>for children <input checked="" type="checkbox"/> applicable</th> </tr> </thead> <tbody> <tr> <td>Finger traps</td> <td>&lt; 8 mm or &gt; 25 mm</td> <td>&lt; 4 mm or &gt; 25 mm</td> </tr> <tr> <td>Foot traps</td> <td>&lt; 35 mm or &gt; 120 mm</td> <td>&lt; 25 mm or &gt; 120 mm</td> </tr> <tr> <td>Head traps</td> <td>&lt; 120 mm or &gt; 300 mm</td> <td>&lt; 60 mm or &gt; 300 mm</td> </tr> <tr> <td>Genitalia traps</td> <td>&lt; 8 mm or &gt; 75 mm</td> <td>&lt; 8 mm or &gt; 75 mm</td> </tr> </tbody> </table>	To avoid	Safe distances		for adults <input checked="" type="checkbox"/> applicable	for children <input checked="" type="checkbox"/> applicable	Finger traps	< 8 mm or > 25 mm	< 4 mm or > 25 mm	Foot traps	< 35 mm or > 120 mm	< 25 mm or > 120 mm	Head traps	< 120 mm or > 300 mm	< 60 mm or > 300 mm	Genitalia traps	< 8 mm or > 75 mm	< 8 mm or > 75 mm	The squeezing points were assessed in the product configuration provided by the manufacturer. The inspection of the squeezing points between moving parts and between moving and fixed parts was carried out with a test gauge.	
To avoid	Safe distances																			
	for adults <input checked="" type="checkbox"/> applicable	for children <input checked="" type="checkbox"/> applicable																		
Finger traps	< 8 mm or > 25 mm	< 4 mm or > 25 mm																		
Foot traps	< 35 mm or > 120 mm	< 25 mm or > 120 mm																		
Head traps	< 120 mm or > 300 mm	< 60 mm or > 300 mm																		
Genitalia traps	< 8 mm or > 75 mm	< 8 mm or > 75 mm																		
			P																	
			P																	
			N/A																	
			N/A																	
	c) if cords (ropes), chains or drive belts are used, either they shall be confined so that they cannot run off or jump out of their guiding devices, or a hazardous situation shall be prevented by other means; mechanical means used for this purpose shall not be removable without the use of a tool; or		N/A																	
	d) the wheelchair shall incorporate a control device which enables the movement when it is operated and stops the movement when it is released (e.g. a spring-loaded device that returns to the stop position when released).		N/A																	
	For moving parts that can cause squeezing, manufacturers shall take into consideration the part or parts of the body that are at risk. It is necessary to specify the characteristics of the persons involved in the intended use, so that the appropriate safe distances can be applied.	Children and adults.	P																	
<b>5.10.2</b>	<b>Mechanical wear</b>																			
	Parts subject to mechanical wear likely to create a hazard shall be accessible for inspection.		P																	

Clause	Requirement + Test	Result – Remark	Verdict																	
<b>5.11</b>	<b>Prevention of traps for parts of the human body</b>																			
<b>5.11.1</b>	<b>Holes and clearances</b>																			
	Holes in, and clearances between stationary parts that are accessible to the occupant and/or assistant during the intended use of the wheelchair shall be as specified in Table 2.																			
	Table 2 Safe distances between stationary parts																			
	<table border="1"> <thead> <tr> <th rowspan="2">To avoid</th> <th colspan="2">Safe distances</th> </tr> <tr> <th>for adults <input checked="" type="checkbox"/> applicable</th> <th>for children <input checked="" type="checkbox"/> applicable</th> </tr> </thead> <tbody> <tr> <td>Finger traps</td> <td>&lt; 8 mm or &gt; 25 mm</td> <td>&lt; 5 mm or &gt; 12 mm</td> </tr> <tr> <td>Foot traps</td> <td>&lt; 35 mm or &gt; 100 mm</td> <td>&lt; 25 mm or &gt; 45 mm</td> </tr> <tr> <td>Head traps</td> <td>&lt; 120 mm or &gt; 250 mm</td> <td>&lt; 60 mm or &gt; 250 mm</td> </tr> <tr> <td>Genitalia traps</td> <td>&lt; 8 mm or &gt; 75 mm</td> <td>&lt; 8 mm or &gt; 75 mm</td> </tr> </tbody> </table>	To avoid	Safe distances		for adults <input checked="" type="checkbox"/> applicable	for children <input checked="" type="checkbox"/> applicable	Finger traps	< 8 mm or > 25 mm	< 5 mm or > 12 mm	Foot traps	< 35 mm or > 100 mm	< 25 mm or > 45 mm	Head traps	< 120 mm or > 250 mm	< 60 mm or > 250 mm	Genitalia traps	< 8 mm or > 75 mm	< 8 mm or > 75 mm	The holes in, and clearances between stationary parts were assessed in the product configuration provided by the manufacturer. The inspection of the holes in, and clearances between stationary parts was carried out with a test gauge.	
To avoid	Safe distances																			
	for adults <input checked="" type="checkbox"/> applicable	for children <input checked="" type="checkbox"/> applicable																		
Finger traps	< 8 mm or > 25 mm	< 5 mm or > 12 mm																		
Foot traps	< 35 mm or > 100 mm	< 25 mm or > 45 mm																		
Head traps	< 120 mm or > 250 mm	< 60 mm or > 250 mm																		
Genitalia traps	< 8 mm or > 75 mm	< 8 mm or > 75 mm																		
	If the intended purpose of the wheelchair cannot be met without a hazard caused by the size of holes and the clearance between stationary parts, a warning and instructions on how to control the risk shall be provided in the instructions for use.		P																	
	For stationary parts that can cause a trap, manufacturers shall take into consideration the parts of the body that are at risk. It is necessary to specify the characteristics of the persons involved in the intended use, so that the appropriate safe distances can be applied.	Children and adults.	P																	
	The design of parts that confine a hole or clearance shall take into consideration the forces that can be applied in normal use.  NOTE: Forces can cause holes or clearances to widen, which can lead to loss of conformity with the requirements of Table 2.		N/A																	

Clause	Requirement + Test	Result – Remark	Verdict
	The lower limits specified in Table 2 do not apply for holes with the shape of a keyhole, or for V-shaped openings. When inspecting the wheelchair for traps for body parts any flexibility and/or elasticity of adjacent parts shall be taken into account.		N/A
<b>5.11.2</b>	<b>V-shaped openings</b>		
	The risk of entrapment in V-shaped openings shall be addressed by the risk management process (see 5.1). NOTE For guidance, see B.2.13.		N/A
<b>5.12.</b>	<b>Folding and adjusting mechanisms</b>		
<b>5.12.1</b>	<b>General</b>		
	Folding and adjusting mechanisms can present a hazard if parts of the body can enter a gap between parts and be trapped when the gap is closed.		
	If the wheelchair incorporates folding and/or adjusting mechanisms it shall conform to 5.12.2 and 5.12.3.		
<b>5.12.2</b>	<b>Locking mechanisms</b>		
	Folding and adjusting mechanisms shall be capable of being securely locked when the wheelchair is in a working configuration.		P
	They shall also be capable of being securely locked when folded if they constitute a risk.		N/A
	The wheelchair shall fold in a safe manner.		P
<b>5.12.3</b>	<b>Guards</b>		
	<b>Either:</b>		
	a) the wheelchair shall incorporate means to protect the occupant from trap and/or squeeze hazards; or		N/A
	b) the gap between exposed parts of the wheelchair that move relative to each other shall be maintained throughout the range of movement at less than the applicable minimum value or more than the applicable maximum value set out in Table 1; or		P

Clause	Requirement + Test	Result – Remark	Verdict
	c) if the intended purpose of the wheelchair cannot be met without a hazard such as squeezing, a warning and instructions on how to control the risk shall be provided in the instructions for use.		N/A
	The design of a guard shall take into consideration the forces that can be applied in normal use.		N/A
<b>5.13</b>	<b>Surfaces, corners, edges and protruding parts</b>		
	If not required for intended use, accessible edges, corners and surfaces of the wheelchair shall be smooth and be free from burrs and sharp edges.	All accessible edges, corners and surfaces have been haptically assessed as smooth, free of burrs and without sharp edges.	P
	If not required for intended use, wheelchairs shall not have protruding parts. Where practicable, protruding parts shall have protection to prevent injury and/or damage. NOTE For guidance, see B.2.14.		N/A
<b>5.14.</b>	<b>Ergonomic principles</b>		
	Wheelchairs shall be designed in accordance with the ergonomic principles set out in EN 614-1:2006+A1:2009, taking into account the specific needs of the intended occupant. The ergonomic principles set out in EN 614-1:2006+A1:2009 also apply to an assistant, those involved in care of the wheelchair occupant, and those involved in transportation and storage of the wheelchair.		
	Grips, handles and foot supports shall suit the functional anatomy of the occupant and/or assistant, in accordance with the intended use, and meet the following requirements:		
	a) the distance between any handle (part intended to be gripped) requiring an operating force of more than 10 N and any other part of the wheelchair shall not be less than 35 mm;		P
	b) the vertical distance between the upper surface of a foot support or pedal in its operating position and any other part of the wheelchair shall not be less than 75 mm;		N/A

Clause	Requirement + Test	Result – Remark	Verdict
	c) the diameter of any operating handle or knob requiring an operating force of more than 10 N shall be between 19 mm and 43 mm;	Brake lever: 30 x 20 mm	P
	d) the upper surface of any pedal intended for operation by an assistant shall not be more than 300 mm above the ground.		N/A
<b>5.15</b>	<b>Applicable provisions for specified types of wheelchair</b>		
	Annex F specifies the provisions in this document that apply to some specified types of wheelchair. Wheelchairs of types listed in F.1 shall meet the applicable requirements of Annex F.		N/A
<b>5.16</b>	<b>Recommendations</b>		
	The following annexes provide recommendations: - Annex A for dimensions and manoeuvring space; - Annex B for design features; - Annex D for castor stem angles.		
<b>6.</b>	<b>Preparation for testing</b>		
<b>6.1</b>	<b>General</b>		
	Unless otherwise specified in Clauses 7, 8, 9, 10 and 11, the wheelchair shall be prepared for testing as specified in ISO 7176-22:2014 with the following modification.		
	If a test procedure requires the use of a test dummy, it shall be selected and fitted as specified in 6.2.  This instruction supersedes instructions for loading the wheelchair in the referenced standards.		
<b>6.2</b>	<b>Test dummy</b>		
	Unless otherwise specified in this document, select a test dummy, as specified in ISO 7176-11:2012, of mass equal to the maximum occupant mass specified by the wheelchair manufacturer, with a tolerance of 0 kg to +5 kg.  Fit the test dummy in the wheelchair as specified in ISO 7176-22:2014.	maximum occupant mass specified by the wheelchair manufacturer: 140 kg	

Clause	Requirement + Test	Result – Remark	Verdict																																												
<b>7.</b>	<b>Wheelchair performance</b>																																														
<b>7.1</b>	<b>Static stability</b>																																														
<b>7.1.1</b>	<b>Requirements</b>																																														
	If the static stability of the wheelchair in the rearward direction is less than 10°, the wheelchair shall have provision for anti-tip devices that increase the static stability in the rearward direction to at least 10°.		P																																												
<b>7.1.2</b>	<b>Test method</b>																																														
	Test the loaded wheelchair as specified in ISO 7176-1:2014. Where the maximum occupant mass is greater than 100 kg, repeat the rearward static stability test with a 100 kg dummy fitted to the wheelchair.																																														
	If the wheelchair is equipped with anti-tip devices which can be removed without the use of a tool, or if the manufacturer does not state that it is necessary to use anti-tip devices, use the results of tests without anti-tip devices recorded in ISO 7176-1:2014, Table 4, to establish whether provision for anti-tip devices is required, and, if so, determine whether the wheelchair has such provision and whether the anti-tip devices provide the required static stability.																																														
	<b>Table 4 of ISO 7176-1:2014</b> <table border="1" style="width: 100%; border-collapse: collapse;"> <thead> <tr> <th colspan="4" style="text-align: center;"><b>Wheelchair tipping angle (degrees)</b></th> </tr> <tr> <th colspan="2" style="text-align: left;"><b>Stability direction</b></th> <th style="text-align: center;">Least stable</th> <th style="text-align: center;">Most stable</th> </tr> </thead> <tbody> <tr> <td rowspan="2" style="text-align: center;">Forward</td> <td>Front wheels locked</td> <td style="text-align: center;">N/A</td> <td style="text-align: center;">N/A</td> </tr> <tr> <td>Front wheels unlocked</td> <td style="text-align: center;">15°*</td> <td style="text-align: center;">N/A</td> </tr> <tr> <td rowspan="2" style="text-align: center;">Rearward</td> <td>Rear wheels locked</td> <td style="text-align: center;">4,9°</td> <td style="text-align: center;">N/A</td> </tr> <tr> <td>Rear wheels unlocked</td> <td style="text-align: center;">10°</td> <td style="text-align: center;">N/A</td> </tr> <tr> <td rowspan="2" style="text-align: center;">Lateral orientation<sup>1</sup></td> <td>Left</td> <td style="text-align: center;">15°*</td> <td style="text-align: center;">N/A</td> </tr> <tr> <td>Right</td> <td style="text-align: center;">15°*</td> <td style="text-align: center;">N/A</td> </tr> </tbody> </table> <table border="1" style="width: 100%; border-collapse: collapse;"> <thead> <tr> <th colspan="4" style="text-align: center;"><b>Anti-tip device tipping angle (degrees)</b></th> </tr> <tr> <th colspan="2" style="text-align: left;"><b>Stability direction</b></th> <th style="text-align: center;">Least effective</th> <th style="text-align: center;">Most effective</th> </tr> </thead> <tbody> <tr> <td rowspan="2" style="text-align: center;">Anti-tip device<sup>2</sup></td> <td>Rearward</td> <td style="text-align: center;">15°*</td> <td style="text-align: center;">N/A</td> </tr> <tr> <td>Forward</td> <td style="text-align: center;">N/A</td> <td style="text-align: center;">N/A</td> </tr> </tbody> </table>		<b>Wheelchair tipping angle (degrees)</b>				<b>Stability direction</b>		Least stable	Most stable	Forward	Front wheels locked	N/A	N/A	Front wheels unlocked	15°*	N/A	Rearward	Rear wheels locked	4,9°	N/A	Rear wheels unlocked	10°	N/A	Lateral orientation <sup>1</sup>	Left	15°*	N/A	Right	15°*	N/A	<b>Anti-tip device tipping angle (degrees)</b>				<b>Stability direction</b>		Least effective	Most effective	Anti-tip device <sup>2</sup>	Rearward	15°*	N/A	Forward	N/A	N/A	
<b>Wheelchair tipping angle (degrees)</b>																																															
<b>Stability direction</b>		Least stable	Most stable																																												
Forward	Front wheels locked	N/A	N/A																																												
	Front wheels unlocked	15°*	N/A																																												
Rearward	Rear wheels locked	4,9°	N/A																																												
	Rear wheels unlocked	10°	N/A																																												
Lateral orientation <sup>1</sup>	Left	15°*	N/A																																												
	Right	15°*	N/A																																												
<b>Anti-tip device tipping angle (degrees)</b>																																															
<b>Stability direction</b>		Least effective	Most effective																																												
Anti-tip device <sup>2</sup>	Rearward	15°*	N/A																																												
	Forward	N/A	N/A																																												
	Does device prevent tipping over?		P																																												
	<sup>1</sup> With lockable wheels locked. <sup>2</sup> With the wheelchair in least stable configuration * maximum angle of the inclined plane																																														

Clause	Requirement + Test	Result – Remark	Verdict
<b>7.2</b>	<b>Static, impact and fatigue strength</b>		
<b>7.2.1</b>	<b>Requirements</b>		
	<p>The wheelchair shall conform to the requirements of ISO 7176-8:2014.            Arm supports shall conform to the static loading requirements of ISO 7176-8:2014 in all intended operating positions.            NOTE ISO 16840-3 provides related test methods for postural support devices.</p>		
<b>7.2.2</b>	<b>Test method</b>		
	<p>Test the wheelchair in accordance with ISO 7176-8:2014. If the maximum occupant mass is greater than 100 kg, make the following modifications to the preparation for the fatigue test.</p> <ol style="list-style-type: none"> <li>Fit a 100 kg test dummy to the wheelchair as specified in ISO 7176-8:2014. Note the location of the centre of mass of the thigh segment relative to the seat reference point (see Figure 1).</li> <li>Measure the load on the front wheels relative to the load on the rear wheels.</li> <li>Remove the 100 kg test dummy and fit a test dummy with mass equal to the maximum occupant mass as specified in ISO 7176-8:2014.</li> <li>Without changing the overall mass of the thigh segment and without moving the overall centre of mass of the thigh segment closer to the seat reference point than the location noted in step [a], adjust the distribution of mass in the thigh segment to approach as closely as practicable the relative loading on the front and rear wheels measured in step [b].</li> <li>If the relative load distribution measured in step [b] has not been achieved, and the positions of the rear wheels are adjustable, adjust the positions of the rear wheels to approach as closely as practicable the relative loading on the front and rear wheels measured in step [b].</li> </ol>		

Clause	Requirement + Test	Result – Remark	Verdict
	<b>Strength requirements [ISO 7176-8:2014, clause 4.1]</b>		
	<p>When tested in accordance with Clauses 8, 9, and 10 of ISO 7176-8:2014, a single wheelchair shall meet all the following requirements at the conclusion of the tests.</p> <p>a) No component shall show evidence of visible cracks, be fractured, or have become detached, with the following exceptions:</p> <ol style="list-style-type: none"> <li>1 Readjustment of postural supports is allowed after each of the tests in Clauses 8 and 9 of ISO 7176-8:2014.</li> <li>2) Re-tightening, readjusting, or refitting of components that are identified in the operator’s manual as operator-adjustable components is allowed at 25% intervals during each of the multi drum, drop, and manual brake fatigue testing procedures (Clause 10 of ISO 7176-8:2014). Operator adjustable components, as identified in the operator’s manual, may not be adjusted using tools unless the tools are supplied with the wheelchair. If there are operator adjustable components, fatigue test equipment may be stopped at 25 % plus or minus 5 % intervals, to determine if re-tightening, readjusting, or refitting of operator-adjustable components is required. Re-tightening, readjusting, or refitting shall then be performed, following the procedures outlined in the operator’s manual. Restart the test equipment after re-tightening, readjusting, or refitting has been performed.</li> <li>3) Re-tightening, readjusting, or refitting of any other component is not allowed.</li> <li>4) During the fatigue testing (Clause 10 of ISO 7176-8:2014), the following wear items, if they are identified in the operator’s manual, may be replaced no more than twice per item: tyres (including solid tyres), inner tubes, drive belts, castor wheel rubber. In the case of castor wheels that are a single integral part, replacement is only permitted because of wear or failure of the running surface, but not for failure of the wheel structure or other elements (e.g. bearings). No other wear items may be replaced.</li> <li>5) Cracks in surface finishes, such as paint, that do not extend into the structural material do not constitute a failure.</li> </ol> <p>b) No externally visible electrical cable shall be cut, abraded, or crushed. No externally visible electrical connector shall be crushed or disconnected.</p> <p>c) All parts intended to move, rotate or be removable, folding or adjustable shall operate as described by the manufacturer.</p> <p>d) All power-operated systems shall operate as described by the manufacturer.</p> <p>e) Handgrips shall not be displaced.</p> <p>f) No component or assembly of parts shall exhibit visible plastic deformation, free play, or loss of adjustment that adversely affects the function of the wheelchair.</p> <p>g) The brake mechanism shall not have moved from the pre-set positions.</p>		

Clause	Requirement + Test	Result – Remark	Verdict						
	<b>Test methods for static strength [ISO 7176-8:2014, clause 8]</b>								
	<b>Arm supports: Resistance to downward forces [ISO 7176-8:2014, cl. 8.4]</b>								
	<p>The force mentioned below or - if the manufacturer claims that the wheelchair exceeds the appropriate minimum requirement a force claimed to -0 %/+3 % is to applied for 5 s to 10 s.</p> <table border="1"> <thead> <tr> <th>Maximum user mass [kg]</th> <th>Force to be applied to each armrest [N]</th> </tr> </thead> <tbody> <tr> <td>---</td> <td>---</td> </tr> </tbody> </table> <p>Where the manufacturer specifies a maximum occupant mass greater than 125 kg the max. force of <math>F = 952</math> N shall be apply.</p>		Maximum user mass [kg]	Force to be applied to each armrest [N]	---	---	N/A Not available		
Maximum user mass [kg]	Force to be applied to each armrest [N]								
---	---								
	<b>Foot supports: Resistance to downward forces [ISO 7176-8:2014, cl. 8.5]</b>								
	<p>The force mentioned below or - if the manufacturer claims that the wheelchair exceeds the appropriate minimum requirement a force claimed to <math>\pm 3\%</math> is to applied for 5 s to 10 s.</p> <table border="1"> <thead> <tr> <th>Maximum user mass [kg]</th> <th>Force to be applied to each footsupport [N]</th> </tr> </thead> <tbody> <tr> <td>140</td> <td>1226</td> </tr> </tbody> </table> <p>Where the manufacturer specifies a maximum occupant mass greater than 125 kg the max. force of <math>F = 1226</math> N shall be apply.</p>		Maximum user mass [kg]	Force to be applied to each footsupport [N]	140	1226	P		
Maximum user mass [kg]	Force to be applied to each footsupport [N]								
140	1226								
	<b>Tipping levers: Resistance to downward forces [ISO 7176-8:2014, cl. 8.6]</b>								
	<p>The force mentioned below or - if the manufacturer claims that the wheelchair exceeds the appropriate minimum requirement a force claimed to <math>\pm 3\%</math> is to applied for 5 s to 10 s.</p> <table border="1"> <thead> <tr> <th>Maximum user mass [kg]</th> <th>Maximum mass wheelchair [kg]</th> <th>Force to be applied to each tipping lever [N]</th> </tr> </thead> <tbody> <tr> <td>140</td> <td>17</td> <td>1000</td> </tr> </tbody> </table> <p>A force of more than 1000 N shall not be apply.</p>		Maximum user mass [kg]	Maximum mass wheelchair [kg]	Force to be applied to each tipping lever [N]	140	17	1000	P
Maximum user mass [kg]	Maximum mass wheelchair [kg]	Force to be applied to each tipping lever [N]							
140	17	1000							
	<b>Handgrips: Resistance to pull off forces [ISO 7176-8:2014, cl. 8.7]</b>								
	<p>The force mentioned below or - if the manufacturer claims that the wheelchair exceeds the appropriate minimum requirement a force claimed to <math>\pm 3\%</math> is to applied for 5 s to 10 s.</p> <table border="1"> <thead> <tr> <th>Maximum user mass [kg]</th> <th>Maximum mass wheelchair [kg]</th> <th>Force to be applied to each handgrip [N]</th> </tr> </thead> <tbody> <tr> <td>140</td> <td>17</td> <td>750</td> </tr> </tbody> </table> <p>A force of more than 750 N shall not be apply.</p>		Maximum user mass [kg]	Maximum mass wheelchair [kg]	Force to be applied to each handgrip [N]	140	17	750	P
Maximum user mass [kg]	Maximum mass wheelchair [kg]	Force to be applied to each handgrip [N]							
140	17	750							

Clause	Requirement + Test	Result – Remark	Verdict										
	<b>Arm supports: Resistance to upward forces [ISO 7176-8:2014, cl. 8.8]</b>												
	<p>The force mentioned below or - if the manufacturer claims that the wheelchair exceeds the appropriate minimum requirement a force claimed to <math>\pm 3\%</math> is to applied for 5 s to 10 s.</p> <table border="1"> <thead> <tr> <th>Maximum user mass [kg]</th> <th>Maximum mass wheelchair [kg]</th> <th>Force to be applied to each arm support [N]</th> </tr> </thead> <tbody> <tr> <td>---</td> <td>---</td> <td>---</td> </tr> </tbody> </table> <p>A force of more than 1000 N shall not be apply.</p>		Maximum user mass [kg]	Maximum mass wheelchair [kg]	Force to be applied to each arm support [N]	---	---	---	N/A				
Maximum user mass [kg]	Maximum mass wheelchair [kg]	Force to be applied to each arm support [N]											
---	---	---											
	<b>Foot supports: Resistance to upward forces [ISO 7176-8:2014, cl. 8.9]</b>												
	<p>The force mentioned below or - if the manufacturer claims that the wheelchair exceeds the appropriate minimum requirement a force claimed to <math>\pm 3\%</math> is to applied for 5 s to 10 s.</p> <table border="1"> <thead> <tr> <th rowspan="2">Maximum user mass [kg]</th> <th rowspan="2">Maximum mass wheelchair [kg]</th> <th colspan="2">Force to be applied on:</th> </tr> <tr> <th>Two piece foot support [N]</th> <th>One piece foot support [N]</th> </tr> </thead> <tbody> <tr> <td>140</td> <td>17</td> <td>500</td> <td>1.000</td> </tr> </tbody> </table> <p>A force of more than 500 N (two piece foot support) and 1000 N (one piece foot support) shall not be apply.</p>		Maximum user mass [kg]	Maximum mass wheelchair [kg]	Force to be applied on:		Two piece foot support [N]	One piece foot support [N]	140	17	500	1.000	P
Maximum user mass [kg]	Maximum mass wheelchair [kg]	Force to be applied on:											
		Two piece foot support [N]	One piece foot support [N]										
140	17	500	1.000										
	<b>Push handles: Resistance to upward load [ISO 7176-8:2014, cl. 8.10]</b>												
	<p>The force mentioned below or - if the manufacturer claims that the wheelchair exceeds the appropriate minimum requirement a force claimed to <math>\pm 3\%</math> is to applied for 5 s to 10 s.</p> <table border="1"> <thead> <tr> <th rowspan="2">Maximum user mass [kg]</th> <th rowspan="2">Maximum mass wheelchair [kg]</th> <th colspan="2">Force to be applied on:</th> </tr> <tr> <th>Two push handles [N]</th> <th>Transverse bar handle [N]</th> </tr> </thead> <tbody> <tr> <td>140</td> <td>17</td> <td>880</td> <td>---</td> </tr> </tbody> </table> <p>A force of more than 880 N (two push handles) and 1760 N (transverse bar handle) shall not be apply.</p>		Maximum user mass [kg]	Maximum mass wheelchair [kg]	Force to be applied on:		Two push handles [N]	Transverse bar handle [N]	140	17	880	---	P
Maximum user mass [kg]	Maximum mass wheelchair [kg]	Force to be applied on:											
		Two push handles [N]	Transverse bar handle [N]										
140	17	880	---										
	<b>Test methods for impact strength [ISO 7176-8:2014, clause 9]</b>												
	<p><b>Back support: Resistance to impact [ISO 7176-8:2014, clause 9.3]</b> (only for wheelchairs with a back support &gt; 320 mm)</p> <p>The mass is touching the back support at a point 30 mm below the top of the backrest. The pendulum is supported so that the rigid bar is at an angle of <math>30^\circ \pm 2^\circ</math> to the vertical and then it falls freely and strikes the back of the wheelchair.</p>												

Clause	Requirement + Test	Result – Remark	Verdict
	<p>For wheelchairs where the back support is mounted on two supporting members the test is repeated twice with the pendulum repositioned so that it strikes the central line of each backrest support 30 mm below the top of the backrest.</p>		P
	<p>For wheelchairs where the back support is mounted on a single central support the test is repeated with the pendulum positioned to strike the backrest points located 0,4 times the backrest max. width from each side of its centreline.</p>		N/A
<b>Handrim: Resistance to impact [ISO 7176-8:2014, cl. 9.4]</b>			
	<p>The handrim test pendulum is set up so that when it is hanging vertically its centre of percussion of one side face on the same horizontal line as the wheel hub and is touching the handrim in line with one of its attachment points. If the handrim has a joint which coincides with an attachment point that attachment point is selected as the location of the test.</p> <p>Ensure that the wheelchair brakes are disengaged.</p> <p>The pendulum is raised by an angle of <math>45^{\circ} \pm 2^{\circ}</math> and falls freely. If the manufacturer claims that the wheelchair exceeds the above mentioned requirements, the angle claimed by the manufacturer <math>\pm 2^{\circ}</math> is used.</p>		P
	<p>The wheel and the handrim are rotated so that the pendulum centre of percussion will strike the handrim midway between two attachment points and the test is repeated. If the handrim has a joint which lies between two attachment points, this part of the handrim is selected for the test.</p> <p>If the handrim is continuously attached to the rim of the wheel, the wheel and the handrim are rotated through <math>90^{\circ} \pm 5^{\circ}</math> between the two impacts.</p>		P

Clause	Requirement + Test	Result – Remark		Verdict						
	<p><b>Castors: resistance to impact [ISO 7176-8:2014, cl. 9.5]</b></p> <p>The castor is set up so that it is to be tested aligned at <math>45^\circ \pm 5^\circ</math> to the longitudinal axis of the wheelchair.</p> <p>The plane of the pendulum's swing has to be in the plane of the castor wheel <math>\pm 2^\circ</math>.</p> <p>The pendulum is located so that it is hanging vertically with its centre of percussion of one side face on the same horizontal line as the castor hub <math>\pm 5^\circ</math> and touching the wheel rim.</p> <p>Calculate the angle of swing of the pendulum from following formula 15 of ISO 7176-8:2014:</p> $\theta = \arccos \left[ 1 - \frac{(M_d + M_w)}{377} \right]$ <p>with: <math>\theta</math> = angle of swing in degrees  <math>M_d</math> = max. dummy mass in kg  <math>M_w</math> = wheelchair mass in kg</p> <p>Raise the pendulum so that its longitudinal axis is at <math>\theta_{\substack{+3^\circ \\ -0^\circ}}</math> to the vertical and then it is released so that it strikes the castor wheel.</p> <p>If the manufacturer claims that the wheelchair exceeds the minimum requirement, set the pendulum at an angle suitable to validate the claim.</p> <p>The test is repeated on all other castors of the wheelchair.</p>	<table border="1"> <tr> <td data-bbox="802 421 890 454"><math>M_d</math></td> <td data-bbox="898 421 1042 454">140 kg</td> </tr> <tr> <td data-bbox="802 465 890 499"><math>M_w</math></td> <td data-bbox="898 465 1042 499">17 kg</td> </tr> <tr> <td data-bbox="802 510 890 544"><math>\theta</math></td> <td data-bbox="898 510 1042 544"><math>54^\circ</math></td> </tr> </table>	$M_d$	140 kg	$M_w$	17 kg	$\theta$	$54^\circ$		P
$M_d$	140 kg									
$M_w$	17 kg									
$\theta$	$54^\circ$									
	<p><b>Foot support: resistance to impact [ISO 7176-8:2014, cl. 9.6]</b></p> <p>These tests apply to wheelchairs which have foot supports which can come into contact with obstacles.</p> <p>If wheelchairs are fitted with two separate foot supports, perform both tests on one foot support.</p> <p>If wheelchairs are fitted with a single foot support, perform both tests on the same side of that foot support.</p> <p>To improve the ability of test laboratories to compare test results, where possible, these tests should be applied <u>to the right side of the wheelchair</u> when facing in the forward direction of the wheelchair.</p>									

Clause	Requirement + Test	Result – Remark	Verdict
	<b>Lateral impact [ISO 7176-8:2014, cl. 9.6.3]</b>		
	<p>Suspend the foot support test pendulum so that:</p> <ul style="list-style-type: none"> <li>a) its centre of percussion touches that part of the foot support which is nearest to the test plane and furthest from the wheelchair longitudinal centreline,</li> <li>b) its plane of swing is normal to the wheelchair longitudinal centreline <math>\pm 2^\circ</math>, and</li> <li>c) the longitudinal axis of the pendulum is vertical.</li> </ul> <p>Figure 27 and Figure 28 in ISO 7176-8:2014 show some illustrations of the point of impact on various designs of foot support.</p> <p>Calculate the angle of swing of the pendulum from Formula 15 of ISO 7176-8:2014.</p> <p>Raise the pendulum so that its longitudinal axis is at <math>\theta \begin{smallmatrix} +3^\circ \\ -0^\circ \end{smallmatrix}</math> to the vertical and release it so that it strikes the foot support.</p> <p>If the manufacturer claims that the wheelchair exceeds the above requirement, set the pendulum at an angle suitable to validate the claim.</p> <p>If the foot support has moved from its setting but is structurally undamaged, reset it to its initial position.</p>	$\theta = 54^\circ$	P
	<b>Longitudinal impact [ISO 7176-8:2014, cl. 9.6.4]</b>		
	<p>Suspend the foot support test pendulum so that</p> <ul style="list-style-type: none"> <li>a) its centre of percussion touches that part of the foot support which is furthest forward and furthest from the wheelchair longitudinal centreline,</li> <li>b) its plane of swing is parallel to the wheelchair longitudinal centreline, and</li> <li>c) the longitudinal axis of the pendulum is vertical.</li> </ul> <p>ISO 7176-8:2014, Figure 27 and Figure 28 show some illustrations of the point of impact on various designs of foot support.</p>	$\theta = 54^\circ$	P

Clause	Requirement + Test	Result – Remark	Verdict
	<b>Upward impacts on anti-tip devices [ISO 7176-8:2014, cl. 9.7.1]</b>		
	<p>This test simulates the impacts anti-tip devices may experience when descending a kerb. Where there is more than one anti-tip device that operates to prevent tipping in a particular direction (e.g. rearward anti-tip devices), they are tested together through this test and are referred to as the anti-tip device.</p> <p>Set up the test dummy for this test. Before commencing the tests, set the anti-tip device to the longest and highest position in accordance with the manufacturer's instructions for use. If both settings cannot be achieved at one time, repeat the test in the longest and the highest position five times in each position rather than the ten times normally applied to anti-tippers. Place the loaded wheelchair on the horizontal test plane.</p> <p>Slowly lift the anti-tip device in vertical direction until the forces become zero under the rear wheels.</p> <p>Measure and record the distance from the bottom point of the anti-tip device to the horizontal test plane as distance <math>h_1</math> (ISO 7176-8:2014, Figure 29 a).</p> <p>Prepare a hard and durable curb that is 15 mm higher than distance <math>h_1</math> and large enough to accommodate the following test.</p> <p>Place the wheelchair on the test plane so that its front wheels rest on the test plane and its rear wheels rest on the curb (ISO 7176-8:2014, Figure 29 b). For a wheelchair with the anti-tipper device in the front, the rear wheels will rest on the test plane and its front wheels rest on the curb.</p> <p>Drive the wheelchair off the curb so that the anti-tip device hits the upper surface of the curb (ISO 7176-8:2014, Figure 29 c).</p> <p>The speed of movement off the curb shall be significant enough to provide an upward impact to the antitippers (e.g. 1 m/s).</p> <p>Perform this test three times in total.</p>	$h_1 = 30 \text{ mm}$	P

Clause	Requirement + Test	Result – Remark	Verdict
	<b>Forward or rearward impacts on anti-tip devices [ISO 7176-8:2014, cl. 9.7.2]</b>		
	Apply the test procedure in ISO 7176-8:2014, 9.5 to the point on each anti-tip device that is furthest from the wheelchair axle centreline, selecting the anti-tip device(s) for test for manual wheelchairs – all forward or lateral facing anti-tip devices;		N/A
	<b>Lateral impacts on anti-tip devices [ISO 7176-8:2014, cl. 9.7.3]</b>		
	<p>This test applies to wheelchairs that are fitted with anti-tip devices at front or rear of the wheelchair.</p> <p>Before commencing the tests, set the anti-tip device to the longest and highest position that is in conformity with the operator's manual. If both settings cannot be achieved at one time, give preference to the higher position.</p> <p>Place the wheelchair on the horizontal test plane with the anti-tip device to be tested aligned at <math>45^\circ \pm 5^\circ</math> to the impact pendulum as shown in ISO 7176-8:2014, Figure 30.</p> <p>Ensure that the wheelchair brakes are disengaged and that any device for disengaging the drive is operated.</p> <p>Locate the castor and foot support impact test pendulum so that it is hanging vertically with its centre of percussion of one side face on the same horizontal line as the contact point with the anti-tip device and touching it.</p> <p>NOTE: When the highest position of the anti-tip device does not permit the vertical alignment specified in this clause, the pendulum may be adjusted as for the castor impact test (Figure 26), or the wheelchair may be raised on a horizontal surface such that the alignment between anti-tip device and pendulum can be achieved.</p>		P

Clause	Requirement + Test	Result – Remark	Verdict
	<p>Calculate the angle of swing of the pendulum for rear impact using Formula (16):</p> $\theta = \arccos \left[ 1 - \frac{(M_d + M_w)}{892} \right]$ <p>Calculate the angle of swing of the pendulum for front impact using Formula (17):</p> $\theta = \arccos \left[ 1 - \frac{(M_d + M_w)}{377} \right]$ <p>with: <math>\theta</math> = angle of swing in degrees  <math>M_d</math> = max. dummy mass in kg  <math>M_w</math> = wheelchair mass in kg</p> <p>If the manufacturer claims that the wheelchair exceeds the minimum requirement, use the angle claimed by the manufacturer with a tolerance of <math>+3^\circ/-0^\circ</math>.</p> <p>Raise the pendulum so that its longitudinal axis is at <math>\theta \begin{smallmatrix} +3^\circ \\ -0^\circ \end{smallmatrix}</math> to the vertical and then it is released so that it strikes the side of the anti-tip device. Repeat the test on all the other anti-tip devices on the wheelchair.</p>	<p>Rear impact: 35°            Front impact: N/A</p>	<p>P</p>
	<b>Fatigue tests [ISO 7176-8:2014, clause 10]</b>		
	<b>Multi-drum test [ISO 7176-8:2014, clause 10.3]</b>		
	<p>The reference drum surface shall run at 1.0 m/s <math>\pm</math> 0,1 m/s.</p> <p>The test is finished, when the reference drum has complete 200.000 revolutions or any higher figure claimed by the manufacturer.</p>	<p>ISO Dummy: 140 kg</p>	<p>P</p>
	<b>Drop test [ISO 7176-8:2014, clause 10.4]</b>		
	<p>The wheelchair is dropped freely from a height of 50 mm <math>\pm</math> 5 mm.</p> <p>The test is completed, when the process had been repeated 6.666 cycles.</p> <p>If the manufacturer claims that the wheelchair exceeds the min. requirements (6.666 cycles) until the number of cycles claimed have been completed.</p>	<p>ISO Dummy: 140 kg</p>	<p>P</p>

Clause	Requirement + Test	Result – Remark	Verdict
	<b>Fatigue test of man. operated parking brakes [ISO 7176-8:2014, cl. 10.5]</b>		
	<p>Move the lever of the brake smoothly from non-braking position to braking position and back for 60.000 cycles at a frequency of not more than 0,5 Hz.</p> <p>Repeat the test for each different design of parking brake fitted to the wheelchair.</p> <p>If the wheelchair is fitted with two symmetrically identical design of brakes (e.g. left and right), it is not necessary to test both brakes.</p>		P
<b>7.3</b>	<b>Tilting fatigue strength</b>		
<b>7.3.1</b>	<b>General</b>		
	Occupied wheelchairs can often be tipped backwards by assistants when manoeuvring them. The tipping action can put considerable stress on the back support and related components. It is important that a manual wheelchair that can be tipped in this way is able to withstand repeated tipping without damage.		
<b>7.3.2</b>	<b>Requirement</b>		
	This requirement applies only to wheelchairs where the intended use includes tipping the occupied wheelchair backwards about the rear wheel axles by use of the push handles.		
	<p>After the wheelchair has been subjected to the test specified in 7.3.3, no part of the back support shall have moved from the pre-set position and no component or assembly of parts shall show visible signs of cracks, breakages, gross deformations, free play, loss of adjustment or any other damage that adversely affects the function of the wheelchair.</p>	ISO Dummy: 140 kg	P

Clause	Requirement + Test	Result – Remark	Verdict
<b>7.3.3</b>	<b>Test method</b>		
	<p>a) If the position of the rear wheels is adjustable, set them to the most rearward position in accordance with the manufacturer's instructions for use. If the position of the front wheels is adjustable, set them to the most forward position in accordance with the manufacturer's instructions.</p> <p>b) If the position of the back support and/or push handles is adjustable, set them to the maximum height in accordance with the manufacturer's instructions.</p> <p>c) Ensure that the rear wheels are free to rotate, for example by disengaging parking brakes.</p> <p>d) Restrain the rear wheels using appropriate means (4.12) so that the wheelchair can be tipped about the axles of the rear wheels without the wheels moving.</p> <p>e) Attach the means to tip the wheelchair (4.13) to the push handles so that it will apply forces in a vertical plane parallel to the forward direction of travel that bisects the wheelchair. Make sure the means of attachment cannot apply any lateral forces to the push handles.</p> <p>f) Select a test dummy in accordance with 6.2, except that the mass shall be the maximum occupant mass or 150 kg, whichever is the lower. Secure the dummy in the wheelchair using appropriate means (4.14) so that it will remain in position as the wheelchair is tipped and returned to the upright position.</p> <p>g) Using the means to tip the wheelchair (4.13), smoothly tip the loaded wheelchair backwards to the point of balance (where the centre of mass of the loaded wheelchair is directly above the rear axles), <math>\pm 1^\circ</math>, to the angle where the front wheels are lifted to a height of +100/120 mm above the test surface, or to the point where the wheelchair cannot be tipped further (e.g. due to an anti-tip device), whichever occurs first. Then smoothly return the loaded wheelchair to the upright position. Ensure the push handles are not pushed forward when the wheelchair is upright.</p> <p>h) Repeat g) for 20 000 cycles at a rate of +20/10 cycles per minute.</p> <p>i) Inspect the wheelchair and determine whether it has met the requirement.</p>		

Clause	Requirement + Test	Result – Remark	Verdict																																
<b>7.4</b>	<b>Wheelchairs for use as seats in motor vehicles</b>																																		
	<p>If the manufacturer specifies that the intended use of the wheelchair includes use as a seat in a motor vehicle, the wheelchair shall conform to the requirements of ISO 7176-19:2008, with the following modifications to subclauses of ISO 7176-19:2008.</p> <p>4.1.2 is replaced by the following: If a wheelchair is intended by the manufacturer to also be secured by a docking securement device in public transportation and/or different private vehicles, the securement points on the wheelchair and/or of the wheelchair tiedown adaptors shall conform to the performance requirements in Clause 5.5.1, second paragraph, is replaced by the following: All webbing of wheelchair-anchored belt restraints shall have a burning rate not exceeding 100 mm/min when tested as specified in ISO 3795.</p> <p>5.2.1 a) is replaced by the following: If the wheelchair has a head restraint, the horizontal excursions of the ATD and the wheelchair, with respect to the impact sled, shall not exceed the limits in Table 7 at any time during the test. If the wheelchair does not have a head restraint, the horizontal excursions of the ATD and the wheelchair with respect to the impact sled shall not exceed the limits in Table 7 at any time during the test, with the exception that the limits specified in Table 7 for excursion of the back of the head of the ATD, Xhead, R, do not apply.</p> <p>5.2.2 e) is replaced by the following: Primary occupant-load-carrying components of the wheelchair shall not show visible signs of failure, unless there is a backup system to provide support. If the wheelchair does not have a head restraint, risks associated with head excursion and neck forces to which the occupant can be exposed during vehicle collisions shall be addressed in the risk management process (see 5.1).</p>	<p>Test lab: Cranfield Impact Centre Test standard: ISO 7176-19:2008 +A1:2015 Test report no.: - D22-002, dated 2022-02-04 - D22-003, dated 2022-02-04</p> <table border="1" data-bbox="802 611 1289 943"> <thead> <tr> <th colspan="4">Used ATD</th> </tr> <tr> <th></th> <th>Occupant weight range kg (lb)</th> <th>ATD size a</th> <th>Approximate mass of ATD kg (lb)</th> </tr> </thead> <tbody> <tr> <td></td> <td>&gt; 18 to 27 (&gt; 40-60)</td> <td>6-year-old child</td> <td>22,5 (50)</td> </tr> <tr> <td></td> <td>&gt; 27 to 43 (&gt; 60-95)</td> <td>10-year-old child</td> <td>35 (76)</td> </tr> <tr> <td></td> <td>&gt; 43 to 57 (&gt; 95-125)</td> <td>Small adult female</td> <td>47,0 (104)</td> </tr> <tr> <td></td> <td>&gt; 57 to 75 (&gt; 125-165)</td> <td>Small adult female, weighted</td> <td>59,0 (130)</td> </tr> <tr> <td><b>X</b></td> <td><b>&gt; 75 to 136 (&gt; 165-300)</b></td> <td><b>Midsized adult male</b></td> <td><b>76,3 (170)</b></td> </tr> <tr> <td></td> <td>&gt; 136 (&gt; 300)</td> <td>Large adult male</td> <td>102,0 (225)</td> </tr> </tbody> </table> <p>a) The midsized male ATD must be a Hybrid II or Hybrid III type. The other sizes of ATDs may be Hybrid II, Hybrid III, VIP, P series, or Q series types. b) The ATD mass may be increased by attaching weighted material, such as lead sheeting, to the exterior of the ATD.</p>	Used ATD					Occupant weight range kg (lb)	ATD size a	Approximate mass of ATD kg (lb)		> 18 to 27 (> 40-60)	6-year-old child	22,5 (50)		> 27 to 43 (> 60-95)	10-year-old child	35 (76)		> 43 to 57 (> 95-125)	Small adult female	47,0 (104)		> 57 to 75 (> 125-165)	Small adult female, weighted	59,0 (130)	<b>X</b>	<b>&gt; 75 to 136 (&gt; 165-300)</b>	<b>Midsized adult male</b>	<b>76,3 (170)</b>		> 136 (> 300)	Large adult male	102,0 (225)	<p>P</p>
Used ATD																																			
	Occupant weight range kg (lb)	ATD size a	Approximate mass of ATD kg (lb)																																
	> 18 to 27 (> 40-60)	6-year-old child	22,5 (50)																																
	> 27 to 43 (> 60-95)	10-year-old child	35 (76)																																
	> 43 to 57 (> 95-125)	Small adult female	47,0 (104)																																
	> 57 to 75 (> 125-165)	Small adult female, weighted	59,0 (130)																																
<b>X</b>	<b>&gt; 75 to 136 (&gt; 165-300)</b>	<b>Midsized adult male</b>	<b>76,3 (170)</b>																																
	> 136 (> 300)	Large adult male	102,0 (225)																																

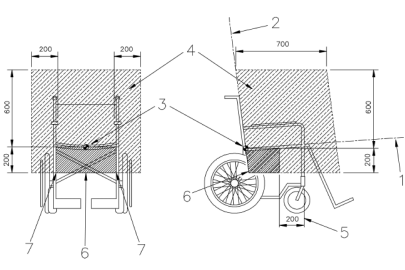
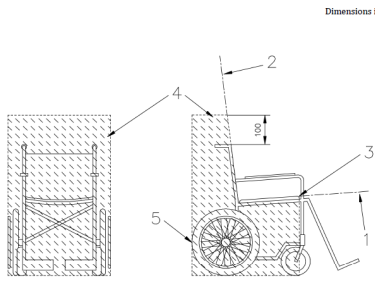
Clause	Requirement + Test	Result – Remark	Verdict
<b>7.5</b>	<b>Surface temperature</b>		
<b>7.5.1</b>	<b>Contact surfaces</b>		
	<p>Surfaces of the wheelchair that can come into direct contact with the occupant's skin and/or an assistant's skin during normal use and that are within the envelopes illustrated in Figure 1 and Figure 2 shall meet the requirements specified in 7.5.2.</p> <div style="display: flex; justify-content: space-around;"> <div style="text-align: center;"> <p>Dimensions in millimetres</p>  <p>Key</p> <ul style="list-style-type: none"> <li>1 seat reference plane</li> <li>2 back support reference plane</li> <li>3 seat reference point</li> <li>4 occupant reach space</li> <li>5 vertical line from the centre of the front edge of the seat</li> <li>6 region below the rear of the seat that is excluded from the reach space</li> <li>7 lateral extent of excluded region delimited by vertical lines from the sides of the seat</li> </ul> <p>Figure 1 — Occupant reach space</p> </div> <div style="text-align: center;"> <p>Dimensions in millimetres</p>  <p>Key</p> <ul style="list-style-type: none"> <li>1 seat reference plane</li> <li>2 back support reference plane</li> <li>3 front edge of seat</li> <li>4 assistant reach space for controls</li> <li>5 most rearward point of wheelchair</li> </ul> <p>Figure 2 — Assistant reach space for controls</p> </div> </div>		
<b>7.5.2</b>	<b>Requirements</b>		
	The risk management process (see 5.1) shall address risks associated with the surface temperature of parts which can come into contact with human skin during intended use.		P
	The risk management process shall take account of:		
	a) the range of ambient temperatures to be expected during intended use and foreseeable misuse; NOTE This can include direct exposure to sunshine, extreme cold, saunas, etc.		P
	b) temperatures that can result from single fault conditions;		N/A
	c) the ergonomic data on acceptable temperatures of touchable surfaces in EN ISO 13732-1:2008;		N/A
	d) use of the wheelchair by people with insensitive skin (i.e. which cannot feel heat) and/or damaged skin.		N/A

Clause	Requirement + Test	Result – Remark	Verdict
	If the intended use includes use by people with insensitive and/or damaged skin, the maximum temperatures of the surfaces involved shall not exceed 41 °C when measured in accordance with EN ISO 13732-1:2008; except that:		N/A
	i. if the manufacturer cannot meet this requirement without impairing the intended performance of the wheelchair, each wheelchair should be supplied with a warning identifying the surfaces that can reach a higher temperature than that specified and a description of the precautions necessary to offset the increased risk; and		N/A
	ii. if the manufacturer cannot meet the surface temperature requirement the reasons shall be set out in the technical documentation (see 5.2).		N/A
<b>8.</b>	<b>Component properties</b>		
<b>8.1</b>	<b>Foot supports, lower leg support assemblies and arm supports</b>		
<b>8.1.1</b>	<b>Requirements</b>		
	The wheelchair shall be fitted with foot supports that have a means of positioning the occupant's feet at the required height and prevent the occupant's feet from sliding backwards.	Calf strap available.	P
	Any swing away, movable or removable foot support, lower leg support assembly or arm support fitted on the wheelchair shall:	Only foot support available.	
	a) incorporate a means to locate it securely in any intended operating position,		P
	b) be adjustable in increments not exceeding 25 mm in any direction,	Stepless.	P
	c) be accessible and operable by the occupant or an assistant or both in accordance with the manufacturer's intended use of the wheelchair,		P

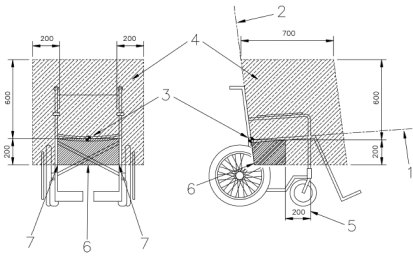
Clause	Requirement + Test	Result – Remark	Verdict
	<p>d) be within the reach space shown as in Figure below and</p> <p style="text-align: right; font-size: small;">Dimensions in millimetres</p>  <p>Key</p> <p>1 seat reference plane  2 back support reference plane  3 seat reference point  4 occupant reach space  5 vertical line from the centre of the front edge of the seat  6 region below the rear of the seat that is excluded from the reach space  7 lateral extent of excluded region delimited by vertical lines from the sides of the seat</p> <p style="text-align: center; font-size: x-small;">Figure 1 — Occupant reach space</p>		P
	e) be operable without the use of tools.	The height adjustment of the foot support is adjusted once to the user.	N/A
	Where the wheelchair has separate foot supports which have a gap between them or the possibility of a gap being formed when they are loaded,		
	f) means to prevent the occupant's feet from sliding into the gap shall be provided, or	U-shaped heel strap available.	P
	g) when the foot supports are tested in accordance with 8.1.2.2, any gap between them shall be less than: - 25 mm if the wheelchair is intended for use by a child; - 35 mm if the wheelchair is not intended for use by a child.	F = --- N	N/A
<b>8.1.2</b>	<b>Test methods</b>		
<b>8.1.2.1</b>	<b>Test for general performance</b>		
	Fit foot supports, lower leg support assemblies and arm supports in the operating position(s) specified in the manufacturer's instructions.		
	Adjust the foot supports, lower leg support assemblies and arm supports as specified in the manufacturer's instructions.		
	Record whether the foot supports, lower leg support assemblies and arm supports have met the requirements.		

Clause	Requirement + Test	Result – Remark	Verdict
<b>8.1.2.2</b>	<b>Test for foot support gap</b>		
	<p>a) Simultaneously apply a force <math>F \begin{smallmatrix} +5 \\ -0^\circ \end{smallmatrix}</math> N to the centroid of each foot support, normal to the plane of the unloaded foot support. In cases where the foot support has no identifiable plane, apply the force within 5° of vertical. The force <math>F</math> is calculated from the following equation:</p> $F = 0,125 \times m \times g$ <p>Where</p> <p><math>F</math> is the force applied to each foot support, expressed in newtons</p> <p><math>m</math> is the maximum occupant mass specified by the manufacturer, expressed in kilograms</p> <p><math>g</math> is the acceleration due to gravity, 9,81 m/s<sup>2</sup>.</p> <p>NOTE: An eighth of the maximum occupant weight represents a typical load for measuring the gap.</p> <p>b) Apply the force for 5 s to 10 s.</p> <p>c) While the force is being applied measure the largest distance between the foot supports as follows:</p> <ol style="list-style-type: none"> <li>i) identify the surfaces of the foot supports that enclose the gap between the foot supports;</li> <li>ii) from each point on the surface of one foot support, measure the distance to the nearest point on the surface of the opposite foot support;</li> <li>iii) record the largest distance measured to an accuracy of ±1 mm.</li> </ol> <p>Record whether the foot supports have met the requirements.</p>		
<b>8.2</b>	<b>Component mass</b>		
	<p>If the wheelchair is intended to be dismantled for storage or transportation, any component that requires moving or handling that has a mass greater than 10 kg shall be provided with suitable handling devices (e.g. handles). The manufacturer shall provide information indicating the points where such components can be lifted and describing how they shall be handled during disassembly, lifting, carrying, and assembly to reduce risks to the person or persons moving or handling them.</p>		N/A
<b>8.3</b>	<b>Pneumatic tyres</b>		
	<p>All pneumatic tyres on the wheelchair shall have the same type of valve connection. Valves should be readily accessible when using the intended inflating tool.</p>		P
	<p>The tyres or the rims shall be marked with the maximum pressure in kPa, bar or PSI.</p>		P

Clause	Requirement + Test	Result – Remark	Verdict
<b>8.4</b>	<b>Means for maintaining a sitting posture</b>		
	<p>The wheelchair shall have provision for a means to be fitted that enables the occupant to maintain a sitting posture.</p> <p>EXAMPLE Anterior pelvic support, pelvic positioning support.</p> <p>NOTE The term 'support' is used for means to sustain occupant posture, and the term 'restraint' is used for means to limit movement of motor vehicle occupants in the event of collision.</p>	<p>Described in the users manual. Available as an option.</p>	P
	<p>If the risk management process (5.1) indicates a risk of the occupant tipping or sliding forwards when the wheelchair is decelerating, the means shall be provided with the wheelchair; otherwise the manufacturer of the wheelchair shall make available such means as an option.</p>		N/A
<b>8.5</b>	<b>Resistance to ignition</b>		
<b>8.5.1</b>	<b>General</b>		
	<p>The surfaces of components which support the occupant, or which stay in contact with the occupant or the occupant's clothing, shall be tested as specified in 8.5.2. Progressive smouldering ignition or flaming ignition as defined in the standard applied shall not occur.</p>	<p>Test material: Backrest upholstery, black            Test standard:            EN 1021-2:2014            Test lab: Hohenstein Textile Testing Institute GmbH &amp; Co. KG            Test report no.: 22.0.13998/2, dated 2022-05-23</p> <p>Test material: Seat upholstery, black            Test standard:            EN 1021-2:2014            Test lab: Hohenstein Textile Testing Institute GmbH &amp; Co. KG            Test report no.: 22.0.15799/3, dated 2022-06-13</p>	P
	<p>It is not necessary to test components that are inherently resistant to ignition, e.g. steel frame tube.</p> <p>NOTE ISO 7176-19 provides related requirements for belt-type restraints. See 7.4.</p>		
<b>8.5.2</b>	<b>Test methods</b>		
<b>8.5.2.1</b>	<b>Selection of test method</b>		
	<p>The test method specified in 8.5.2.2 is the preferred test method. It is the referee test method, which is used to resolve doubts or dispute.</p> <p>The test methods specified in 8.5.2.3 may be used as alternatives.</p>		

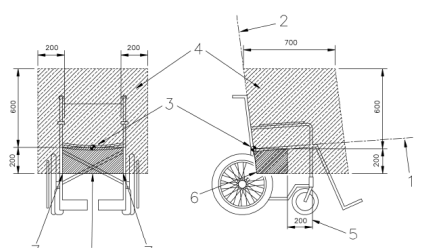
Clause	Requirement + Test	Result – Remark	Verdict
<b>8.5.2.2</b>	<b>Referee test methods</b>		
	Select and test a sample of the component as specified in ISO 16840-10:2021. NOTE The introduction to ISO 16840-10:2021 provides a rationale for use of the test method.		
<b>8.5.2.3</b>	<b>Alternative test methods</b>		
	Test the material of each component in accordance with EN 1021-2:2014 or ISO 8191-2:1988.		
<b>9.</b>	<b>Propulsion and braking systems</b>		
<b>9.1</b>	<b>Means for operating brakes</b>		
<b>9.1.1</b>	<b>Requirement</b>		
	a) Means for operating brakes shall:		
	1) be accessible and operable by the occupant or an assistant or both in accordance with the manufacturer's intended use of the wheelchair;		P
	2) be within the reach space shown in Figure below, if the wheelchair is intended to be operated by the occupant;		P
	<p style="text-align: center;">Dimensions in millimetres</p>  <p><b>Key</b></p> <ul style="list-style-type: none"> <li>1 seat reference plane</li> <li>2 back support reference plane</li> <li>3 seat reference point</li> <li>4 occupant reach space</li> <li>5 vertical line from the centre of the front edge of the seat</li> <li>6 region below the rear of the seat that is excluded from the reach space</li> <li>7 lateral extent of excluded region delimited by vertical lines from the sides of the seat</li> </ul> <p style="text-align: center;">Figure 1 — Occupant reach space</p>		

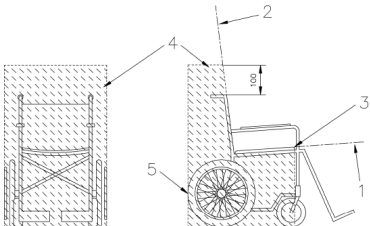
Clause	Requirement + Test	Result – Remark	Verdict																														
	<p>3) be within the reach space shown in Figure below, if the wheelchair is intended to be operated solely by an assistant;</p> <p style="text-align: center;">Dimensions in millimetres</p>  <p>Key  1 seat reference plane  2 back support reference plane  3 front edge of seat  4 assistant reach space for controls  5 most rearward point of wheelchair</p> <p style="text-align: center;">Figure 2 – Assistant reach space for controls</p>		P																														
	<p>4) have operating forces for engaging and disengaging that do not exceed those stated in Table below when tested in accordance with 9.1.2.</p> <table border="1" data-bbox="308 1077 788 1417"> <thead> <tr> <th>Maximum operating force</th> <th>Requirement</th> </tr> </thead> <tbody> <tr> <td>single finger operation</td> <td>5 N</td> </tr> <tr> <td>more than one-finger operation</td> <td>13,5 N</td> </tr> <tr> <td>whole-hand operation</td> <td>60 N</td> </tr> <tr> <td>combined hand-and-arm operation</td> <td>60 N</td> </tr> <tr> <td>foot operation, pushing</td> <td>100 N</td> </tr> <tr> <td>foot operation, pulling</td> <td>60 N</td> </tr> </tbody> </table> <p>NOTE: The brake lever type shown in Figure 4 has a whole-hand operation.</p>	Maximum operating force	Requirement	single finger operation	5 N	more than one-finger operation	13,5 N	whole-hand operation	60 N	combined hand-and-arm operation	60 N	foot operation, pushing	100 N	foot operation, pulling	60 N	<p>Engaging</p> <table border="1" data-bbox="810 952 1118 1081"> <tbody> <tr><td>1</td><td>58 N</td></tr> <tr><td>2</td><td>57 N</td></tr> <tr><td>3</td><td>59 N</td></tr> <tr><td><b>Average</b></td><td><b>58 N</b></td></tr> </tbody> </table> <p>Disengaging</p> <table border="1" data-bbox="810 1128 1118 1258"> <tbody> <tr><td>1</td><td>19 N</td></tr> <tr><td>2</td><td>17 N</td></tr> <tr><td>3</td><td>18 N</td></tr> <tr><td><b>Average</b></td><td><b>18 N</b></td></tr> </tbody> </table>	1	58 N	2	57 N	3	59 N	<b>Average</b>	<b>58 N</b>	1	19 N	2	17 N	3	18 N	<b>Average</b>	<b>18 N</b>	P
Maximum operating force	Requirement																																
single finger operation	5 N																																
more than one-finger operation	13,5 N																																
whole-hand operation	60 N																																
combined hand-and-arm operation	60 N																																
foot operation, pushing	100 N																																
foot operation, pulling	60 N																																
1	58 N																																
2	57 N																																
3	59 N																																
<b>Average</b>	<b>58 N</b>																																
1	19 N																																
2	17 N																																
3	18 N																																
<b>Average</b>	<b>18 N</b>																																
	<p>b) If one or more brake levers are fitted to a wheelchair in the form used on bicycles and mopeds:</p>																																
	<p>1) for wheelchairs with a maximum occupant mass not greater than 150 kg, the force applied to each lever to hold the loaded wheelchair stationary on the maximum slope specified by the manufacturer for parking brake use shall not exceed 60 N;</p>		N/A																														

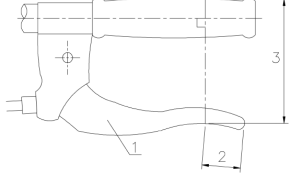
Clause	Requirement + Test	Result – Remark	Verdict
	<p>2) for wheelchairs with a maximum occupant mass greater than 150 kg, the force applied to each lever to hold the loaded wheelchair stationary on the maximum slope specified by the manufacturer for parking brake use should not exceed 60 N;</p>		N/A
	<p>3) the handgrip width of such brake levers when no force is applied, measured 15 mm from the end of the brake lever, shall not be greater than 100 mm and should not be greater than 80 mm (see Figure below).</p>  <p>Key  1 lever gripped by the fingers of one hand  2 15 mm  3 handgrip width</p> <p>Figure 4 – Handgrip width</p>		N/A

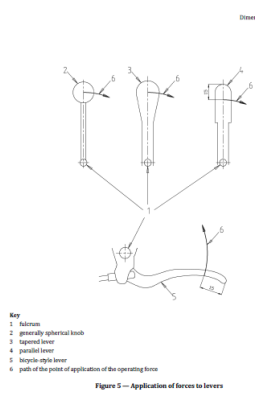
Clause	Requirement + Test	Result – Remark	Verdict
<p><b>9.1.2</b></p>	<p><b>Test method for determination of brake operating forces</b></p> <p>a) Adjust the brakes as specified by the manufacturer.</p> <p>b) Select the part of the lever through which the force is to be applied as shown in Figure below.</p> <div data-bbox="638 515 893 907" style="text-align: center;">  <p style="font-size: small;">Dimensions in millimetres</p> <p style="font-size: x-small;">Key 1 knob 2 generally spherical knob 3 tapered lever 4 parallel lever 5 bicycle-style lever 6 path of the point of application of the operating force</p> <p style="font-size: x-small;">Figure 5 – Application of forces to levers</p> </div> <p>1) If the lever is fitted with a generally spherical knob, apply the force through the centre of the knob.</p> <p>2) If the lever is tapered, apply the force through the point where the largest cross section intersects the centre line of the lever.</p> <p>3) If the lever is parallel or any shape other than those above, apply the force through a point on the centre line of the lever 15 mm below the top.</p> <p>4) If the form of the lever is such that the lever is gripped by the whole hand apply the force through the centre line of the lever 15 mm from the end.</p> <p>5) If the brake is operated by pushing or pulling a bar or pad, apply the force to the centroid of the bar or pad.</p> <p>c) Apply the brakes while measuring the force with the device specified in 4.4 aligned in the direction of travel of the point of application of the force in order to measure the maximum application force required.</p> <p>d) Release the brakes and measure the force with the device as specified in 4.4 aligned in the direction of travel of the point of application of the force in order to measure the maximum releasing force required.</p> <p>e) Perform c) and d) three times in total and record the measurements.</p> <p>f) Calculate and record the arithmetic mean value of the application and the release forces measured separately.</p> <p>g) Determine whether the requirements for the operating forces stated in Table 1 have been met.</p> <p>NOTE A wheelchair operated by the occupant using circular handrims attached to the wheels is considered to have provision to stop the wheelchair because the occupant can slow it down. A wheelchair intended to be controlled by an assistant can require a running brake to allow the assistant to slow or stop the wheelchair.</p>		

Clause	Requirement + Test	Result – Remark	Verdict
<b>9.2</b>	<b>Braking functions</b>		
<b>9.2.1</b>	<b>Requirements</b>		
	a) The wheelchair shall have parking brakes that meet the parking brake effectiveness requirement in Table 3 when tested in accordance with 9.2.2.1.		P
	<b>Test for determination of effectiveness of parking brakes</b>		
	Test plane inclination	Direction of travel	
	7°	uphill	8,5°
		downhill	9,5°
	maximum slope speci-fied by manufacturer	uphill	N/A
		downhill	N/A
		downhill	N/A
	b) If they are subject to wear, parking brakes shall have provision for adjustment and/or replacement as specified by the manufacturer.		P
	c) If the wheelchair is fitted with arm supports that can be moved or removed to enable transfer of the occupant into or out of the wheelchair, when tested in accordance with 9.2.2.2, engaged parking brakes shall not have parts that protrude above the level of the occupied seat that can make contact with the occupant during transfer.		N/A

Clause	Requirement + Test	Result – Remark	Verdict
	d) When parking brakes are tested in accordance with 9.2.2.3, no parking brake mechanism shall move from the pre-set position and no component or assembly of parts shall show visible signs of cracks, breakages, gross deformations, free play, loss of adjustment or any other damage that adversely affects the function of the wheelchair.		P
	e) After testing of the parking brakes in accordance with 9.2.2.3, parking brakes shall meet the parking brake effectiveness requirement in Table 3 when tested again in accordance with 9.2.2.1.		P
<b>Effectiveness of brakes after fatigue strength testing</b>			
	Test plane inclination	Direction of travel	
	7°	uphill	8,5°
		downhill	9,5°
	maximum slope speci-fied by manufacturer	uphill	N/A
<b>9.2.2</b>	<b>Test methods</b>		
<b>9.2.2.1</b>	<b>Determination of effectiveness of parking brakes</b>		
	<p>a) Adjust the parking brake in accordance with the manufacturer's instructions without exceeding the operating force requirements stated in Table 1.</p> <p>b) Test the loaded wheelchair facing uphill in accordance with ISO 7176-3:2012, with the test plane inclined to the horizontal at <math>(7 \frac{+1}{-0})^\circ</math>, or at the maximum angle specified by the manufacturer for parking brake use if it is greater.</p> <p>If the wheelchair has adjustable stability or if the manufacturer declares that the wheelchair static stability is less than 7°, apply to the wheelchair the minimum force, perpendicular to the test plane, necessary for all wheels to remain in contact with the test plane during the test procedure.</p> <p>c) Repeat b) with the wheelchair facing downhill.</p> <p>d) Determine whether the parking brakes hold the loaded wheelchair stationary on the slope.</p>		

Clause	Requirement + Test	Result – Remark	Verdict														
<b>9.2.2.2</b>	<b>Protrusion of parts of parking brakes</b>																
	a) Engage the parking brake. b) Move or remove the arm support to enable transfer. c) Identify any parts of the parking brake that protrude above the plane of the lower surface of the thigh loading plate of the test dummy. d) Determine whether the parking brake meets the requirement.																
<b>9.2.2.3</b>	<b>Fatigue strength of parking brakes</b>																
e)	a) The parking brake may be tested in accordance with b) to g) below, or as specified in ISO 7176-8:2014, 10.5. b) Carry out the test with the parking brake mounted on the wheelchair or mounted on a suitable test fixture that simulates mounting on the wheelchair. If the wheelchair is fitted with two identical brakes (left and right), test only one of the brakes. c) Adjust the parking brake in accordance with the manufacturer's instructions without exceeding the operating force requirement stated in Table 3. d) Set up the means for moving the brake lever (4.10) so that no twisting or bending forces are applied to the brake lever. e) Move the lever of the brake smoothly from the non-braking position to the braking position for 60 000 cycles at a frequency not greater than 0,5 Hz. Carry out maintenance during testing only in accordance with the manufacturer's instructions. f) Inspect the brake mechanism and determine whether it has met the requirement. g) If a test fixture was used, return the brake mechanism to the wheelchair.																
<b>9.3</b>	<b>Pushing force</b>																
<b>9.3.1</b>	<b>Requirements</b>																
	When determined in accordance with 9.3.2, the pushing force required to start the loaded wheelchair moving and to maintain a constant speed on a horizontal surface shall not exceed the following limits:	<table border="1"> <tbody> <tr><td>1</td><td>22 N</td></tr> <tr><td>2</td><td>24 N</td></tr> <tr><td>3</td><td>23 N</td></tr> <tr><td>4</td><td>27 N</td></tr> <tr><td>5</td><td>23 N</td></tr> <tr><td>6</td><td>24 N</td></tr> <tr><td><b>Average</b></td><td><b>24 N</b></td></tr> </tbody> </table>	1	22 N	2	24 N	3	23 N	4	27 N	5	23 N	6	24 N	<b>Average</b>	<b>24 N</b>	
1	22 N																
2	24 N																
3	23 N																
4	27 N																
5	23 N																
6	24 N																
<b>Average</b>	<b>24 N</b>																
	- 40 N for $m \leq 100$ kg,		N/A														
	- 60 N for $100 \text{ kg} < m \leq 150$ kg,		P														
	- 70 N for $150 \text{ kg} < m \leq 200$ kg,		N/A														
	- 80 N for $200 \text{ kg} < m \leq 250$ kg,		N/A														
	$m$ is the maximum occupant mass specified by the wheelchair manufacturer.																

Clause	Requirement + Test	Result – Remark	Verdict
<b>9.3.2</b>	<b>Test method</b>		
	<p>a) Make provisions for applying a horizontal force in the forward direction of travel and along the longitudinal centreline of the wheelchair as follows:</p> <ol style="list-style-type: none"> <li>1) where push handles are fitted, to the push handles;</li> <li>2) where push handles are not fitted and the wheelchair has a flexible back support, to a point 15 mm ± 5 mm below the top of the back support; or</li> <li>3) where the back support is rigid, to a point 15 mm ± 5 mm below the top of the back support.</li> </ol> <p>A bar or string may be fitted across push handles or the back support to permit a pushing force to be applied.</p> <p>b) Place the loaded wheelchair on the horizontal test plane.</p> <p>c) Set up a means to apply a force to start the wheelchair moving and to maintain the wheelchair moving forwards at a speed of 1,0 m/s ± 0,1 m/s so that the direction of the force is maintained within the following limits throughout the test:</p> <ol style="list-style-type: none"> <li>1) horizontal ± 5°;</li> <li>2) at the height of the point to which the force is applied, and parallel to the forward direction of travel of the wheelchair ± 5°;</li> <li>3) within 5 mm of the longitudinal centre line of the wheelchair.</li> </ol> <p>d) Apply the force, and increase it at a rate not greater than 5 N/s until the wheelchair starts to move.</p> <p>e) Accelerate the wheelchair to a speed of 1,0 m/s ± 0,1 m/s over a distance not less than 0,5 m. After the acceleration is complete, measure and record the force needed to maintain the wheelchair in motion at a constant speed of 1,0 m/s ± 0,1 m/s over a distance not less than 2,5 m.</p> <p>f) Maintain the direction of the force within the limits specified above during the whole test procedure.</p> <p>g) Perform the test six times in the forward direction of the wheelchair. Carry out the tests on the same area of the test track, three times in one direction and three times in the opposite direction.</p> <p>h) Calculate the arithmetic mean value of the forces measured.</p>		
<b>10.</b>	<b>Operations</b>		
<b>10.1</b>	<b>Operations intended to be carried out by the occupant and/or assistant</b>		
	Wheelchairs shall be designed to facilitate ease of operation by the occupant and/or assistant as specified in the manufacturer's instructions.		P

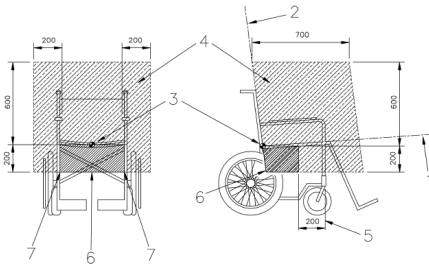
Clause	Requirement + Test	Result – Remark	Verdict
	<p>Examples include:</p> <ul style="list-style-type: none"> <li>- operation of adjustable seating;</li> <li>- use of detachable components, including removable arm supports, lower leg support assemblies, etc., to facilitate safe transfers into and out of the wheelchair;</li> <li>- use of folding mechanisms, including folding frames, etc., to facilitate storage and transportation of an unoccupied wheelchair;</li> <li>- carrying out maintenance, including use of tools, etc.;</li> <li>- use of braking systems;</li> <li>- use of push handles; and</li> <li>- use of electrical ancillary equipment.</li> </ul>		
<b>10.2</b>	<b>Controls intended for operation by the occupant</b>		
	<p>Controls intended to be operated by the occupant while seated shall be within the occupant reach space as shown in Figure below.</p>  <p>Key</p> <ol style="list-style-type: none"> <li>1 seat reference plane</li> <li>2 back support reference plane</li> <li>3 seat reference point</li> <li>4 occupant reach space</li> <li>5 vertical line from the centre of the front edge of the seat</li> <li>6 region below the rear of the seat that is excluded from the reach space</li> <li>7 lateral extent of excluded region delimited by vertical lines from the sides of the seat</li> </ol>		P
	<p>The following controls, if they are fitted and intended to be operated by the occupant, are included:</p> <ul style="list-style-type: none"> <li>- brakes;</li> <li>- seating adjustments;</li> <li>- detachable components, including removable arm supports, lower leg support assemblies, etc., to facilitate safe transfers into and out of the wheelchair;</li> <li>- means of driving and steering; and</li> <li>- electrical ancillary equipment.</li> </ul>		

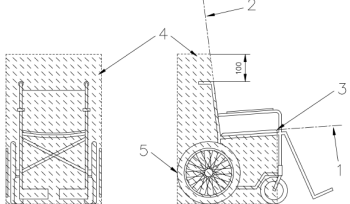
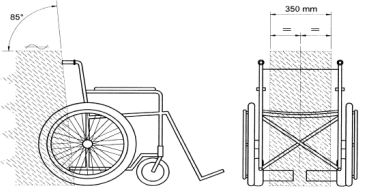
Clause	Requirement + Test	Result – Remark	Verdict
<b>10.3</b>	<b>Controls intended for operation by an assistant</b>		
	<p>Controls intended to be operated by an assistant shall be within the region specified as shown in Figure below.</p>  <p>Key  1 seat reference plane  2 back support reference plane  3 front edge of seat  4 assistant reach space for controls  5 most rearward point of wheelchair</p> <p>Figure 2 — Assistant reach space for controls</p>		P
	<p>Examples include:</p> <ul style="list-style-type: none"> <li>- brakes;</li> <li>- seating adjustments;</li> <li>- detachable components, including removable arm supports, lower leg support assemblies, etc., to facilitate safe transfers into and out of the wheelchair;</li> <li>- means of driving and steering;</li> <li>- push handles; and;</li> <li>- electrical ancillary equipment.</li> </ul>		
<b>10.4</b>	<b>Push handles and handgrips</b>		
<b>10.4.1</b>	<b>Requirements</b>		
	<p>When push handles are fitted, no part of the wheelchair shall lie within a space to the rear of the wheelchair bounded by the following:</p>		P
	<ul style="list-style-type: none"> <li>- a plane at 85° to the horizontal, that touches the rearmost points of the push handles as shown in Figure below.</li> <li>- two planes not less than 350 mm apart equidistant from a vertical plane parallel to the forward direction of travel that bisects the wheelchair, unless the intended occupant is a child;</li> <li>- the horizontal test plane.</li> </ul>  <p>Figure 5 — Space for assistant movement</p>		

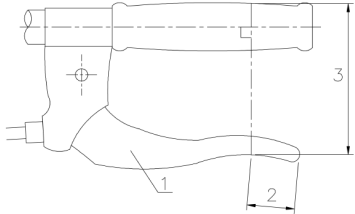
Clause	Requirement + Test	Result – Remark	Verdict
	<p>When the wheelchair is fitted with push handles, the handgrips shall be at least 75 mm in length and between 20 mm and 50 mm in diameter.</p>	<p>Length: 105 mm Diameter: 30 mm</p>	<p>P</p>
	<p>When push handles are fitted with controls that are intended to be used by being gripped by one hand, the grip width when no force is applied shall not be greater than 100 mm and should not be greater than 80 mm as shown in Figure below.</p>  <p>Key 1 lever gripped by the fingers of one hand 2 15 mm 3 grip width</p> <p>Figure 3 — Grip width</p>		<p>N/A</p>
<b>10.4.2</b>	<b>Test method</b>		
	<ol style="list-style-type: none"> <li>Place the wheelchair on the horizontal test plane.</li> <li>Project the planes specified in 10.4.1 and determine whether any part of the wheelchair lies within the enclosed space.</li> <li>Measure the dimensions of the handgrips on the push handles.</li> <li>Where applicable, measure the grip width of the controls fitted to the push handles that are intended to be used by being gripped by one hand.</li> <li>Record whether the wheelchair has met the requirements.</li> </ol>		

Clause	Requirement + Test	Result – Remark	Verdict														
<b>10.5</b>	<b>Operating forces</b>																
<b>10.5.1</b>	<b>Requirements</b>																
	<p>All controls, except for means to operate brakes, shall have operating forces for engaging and releasing that do not exceed those stated in Table 3 when tested in accordance with 10.5.2.</p> <p>NOTE Requirements and test methods for means to operate brakes are given in 9.1.</p>		P														
	<table border="1"> <thead> <tr> <th>Maximum operating forces</th> <th>Requirement</th> </tr> </thead> <tbody> <tr> <td>single finger operation</td> <td>5 N</td> </tr> <tr> <td>more than one finger operation</td> <td>13,5 N</td> </tr> <tr> <td>whole hand operation</td> <td>60 N</td> </tr> <tr> <td>combined hand and arm operation</td> <td>60 N</td> </tr> <tr> <td>foot operation, pushing operation</td> <td>100 N</td> </tr> <tr> <td>foot operation, pulling operation</td> <td>60 N</td> </tr> </tbody> </table>	Maximum operating forces	Requirement	single finger operation	5 N	more than one finger operation	13,5 N	whole hand operation	60 N	combined hand and arm operation	60 N	foot operation, pushing operation	100 N	foot operation, pulling operation	60 N		
Maximum operating forces	Requirement																
single finger operation	5 N																
more than one finger operation	13,5 N																
whole hand operation	60 N																
combined hand and arm operation	60 N																
foot operation, pushing operation	100 N																
foot operation, pulling operation	60 N																
	<p>In addition, to achieve the intended function of the system or device being operated, for knobs intended to be gripped and turned by one hand:</p>																
	<ul style="list-style-type: none"> <li>- where the diameter of the knob is greater than or equal to 25 mm and the force is transmitted by friction, the numerical value of the torque, expressed in Nm, shall not be greater than 0,05 times the numerical value of the diameter of the knob, expressed in mm; and</li> </ul>		N/A														
	<ul style="list-style-type: none"> <li>- where the diameter of the knob is less than 25 mm diameter, the numerical value of the torque, expressed in Nm, shall not be greater than 0,025 times the numerical value of the diameter of the knob, expressed in mm.</li> </ul>		N/A														

Clause	Requirement + Test	Result – Remark	Verdict
<b>10.5.2</b>	<b>Test method</b>		
	a) Position a means to apply force or torque as applicable: <ol style="list-style-type: none"> <li>1) where the operation is performed by pushing or pulling, position the means to apply force parallel to the direction of operation and in the middle of the knob or button;</li> <li>2) in the case of a lever of length 30 mm or greater, position the means to apply force at a distance of 15 mm from the end of the lever;</li> <li>3) in the case of a lever of length less than 30 mm, position the means to apply force at the midpoint of the lever;</li> <li>4) for a turning knob, use a suitable means (e.g. a force gauge) to measure torque concentrically on the knob.</li> </ol> b) Gradually increase the force or torque until the intended function of the system or device as specified by the manufacturer's instructions is achieved.           c) Measure and record the maximum operating force.           d) Perform b) to c) three times in total.           e) Calculate and record the arithmetic mean of the three recorded measurements.		
<b>10.6</b>	<b>Seating adjustments for tilting and reclining</b>		
<b>10.6.1</b>	<b>Requirements</b>		
	If the manufacturer specifies that the seating can be adjusted by an assistant or the occupant or both while the occupant is seated:		
	- the assistant and/or the occupant shall not have to apply or withstand a force (e.g. the combined weight of the occupant and the seating) which presents a moving and handling safety hazard to the assistant and/or the occupant; and		N/A
	- movement of the seating, whether continuous or incremental, shall automatically be prevented when the assistant or occupant releases the means of operation. EXAMPLE Ratchet that locks automatically when the assistant lets go of a handle.		N/A
	Controls for seating adjustments intended to be operated by the occupant shall be accessible to the occupant from all seating positions. NOTE The lighter-shaded region of Figure 1 shows the reach space for the occupant in relation to the position of the back support reference plane and the seat reference plane (see ISO 7176-7:1998).		N/A

Clause	Requirement + Test	Result – Remark	Verdict
<b>10.6.2</b>	<b>Test method</b>		
	a) Adjust the seating in accordance with the manufacturer's instructions. b) Record whether the wheelchair has met the requirements.		
<b>11.</b>	<b>Electrical systems — Electrically powered ancillary equipment</b>		
	If the wheelchair has electrically powered ancillary equipment that can propel the wheelchair or move parts of the body support system, the wheelchair combined with the ancillary equipment shall conform to the applicable requirements of EN 12184:2022.		N/A
<b>12</b>	<b>Information supplied by the manufacturer</b>		
<b>12.1</b>	<b>General</b>		
	Each wheelchair shall be provided with documentation and labelling that conform to the applicable requirements in EN ISO 20417:2021 in addition to the requirements specified in this document.  The manufacturer shall provide the documentation in three separate sections: pre-sale, user and servicing information, as specified in 12.2, 12.3 and 12.4 respectively. These may be provided as separate printed documents or in other forms of media to meet the needs of individual occupants or their assistants.		
	<b>ISO 20417 (applicable parts)</b>		
	<b>4 General considerations</b>		
	a) The risk management process of ISO 14971:2019 and the usability engineering process of IEC 62366-1:2015+AMD1: 2020 should be used to determine the information, including information for safety, to be provided in the information supplied by the manufacturer.	Risk analysis, dated 2023-02-13 available.	P
	b) Where this document specifies a specific edition of a normatively referenced document, the manufacturer may substitute a more current version provided the manufacturer can demonstrate that the residual risk that results from the substitution remains acceptable and is comparable to the residual risk that results from applying the normatively referenced document.		
	c) Information supplied by the manufacturer shall be in a language that is appropriate to the intended user.	English version was available for testing.	P



Clause	Requirement + Test	Result – Remark	Verdict
	d) The accompanying information shall specify any:		
	1) special skills, special training and special knowledge required of the intended user or the responsible organization that are necessary to be able to achieve the intended use of the medical device; and		P
	2) if applicable, restrictions on the use environment that the medical device is intended to be used.		P
	e) The information supplied by the manufacturer shall be written and presented in terms that are readily understood by the intended users, taking into account their education, training and any special needs, as appropriate.		P
	<b>5 Information elements to be established</b>		
	<b>5.1 Units of measurement</b>		
	a) Numeric indications of parameters in the information supplied by the manufacturer shall be expressed in:		
	1) international system of units (SI) as specified in ISO 80000-1;		P
	2) any other units required by a relevant group standard or product standard; or		P
	3) any other units established by clinical convention.		N/A
	b) For application of SI units, their multiples and certain other units, ISO 80000-1 shall apply.		
	<b>5.2 Graphical information</b>		
	a) Any graphical information that is replacing text such as pictograms, symbols, safety signs and safety-related identification colours used in the information supplied by the manufacturer shall have the meaning explained in the accompanying documentation.		P

Clause	Requirement + Test	Result – Remark	Verdict
	b) Symbols used in the information supplied by the manufacturer should be found in: <ol style="list-style-type: none"> <li>1) ISO 7000 (database);</li> <li>2) ISO 7010;</li> <li>3) ISO 15223-1;</li> <li>4) IEC 60417 (database);</li> <li>5) IEC/TR 60878:2015[25]; or</li> <li>6) if applicable:               <ol style="list-style-type: none"> <li>i) relevant product standards; or</li> <li>ii) relevant group standards.</li> </ol> </li> </ol>		
	c) Symbols should be used in the information supplied by the manufacturer.		P
<b>5.3 Language and country identifiers</b>			
<b>5.3.1 Language identifiers</b>			
	In multilingual information supplied by the manufacturer, the language name used:	Only one language in the IFU (English).	N/A
	a) should be clearly linked to the language used; and		N/A
	b) may be identified using:		
	1) the plain text name of the language; or		N/A
	2) the language codes given in <ol style="list-style-type: none"> <li>i) ISO 639-1,</li> <li>ii) ISO 639-2, or</li> <li>iii) ISO 639-3.</li> </ol>		N/A
<b>5.3.2 Country identifiers</b>			
	Where contact details for multiple countries are provided in the information supplied by the manufacturer, the country shall be identified using:		
	a) the country codes given in ISO 3166-1; or		N/A
	b) the plain text of the country name in a language of that country.		N/A



Clause	Requirement + Test	Result – Remark	Verdict
	<b>5.4 Dates</b>		
	<p>Any human-readable date, other than the text associated with the UDI carrier, in the information supplied by the manufacturer shall be expressed in accordance with ISO 8601-1 in the format:</p> <p>a) YYYY-MM-DD;            b) YYYY-MM; or            c) YYYY;</p>		P
	<b>5.5 Full address</b>		
	<p>a) Where this document refers to a full address, the address shall contain the following elements insofar as they are available in the address system of the locale where the relevant entity (manufacturer, distributor, importer or authorized representative) is physically located:</p> <ol style="list-style-type: none"> <li>1) street/road;</li> <li>2) number/house/floor;</li> <li>3) city;</li> <li>4) state/region;</li> <li>5) postal code; and</li> <li>6) country.</li> </ol>		P
	<p>b) The information regarding street/road and number/house/floor may be omitted if a postal code (corporate postal code) is used that fully replaces the indication of street/road and number/house/floor and is not a post office (PO) box number.</p>		N/A
	<b>5.6 Commercial product name</b>		
	<p>A medical device may be identified with a commercial product name specific to the medical device or the manufacturer. A commercial product name is used to assist in the identification of a medical device.</p>		P





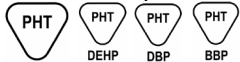

Clause	Requirement + Test	Result – Remark	Verdict
	<b>5.7 Model number</b>		
	a) A model number may be used to represent a medical device, an accessory or a medical device family that have shared characteristics. b) A model number may be associated with multiple catalogue numbers. c) The model number may be identical to the catalogue number, when there is a single catalogue number represented by the model number.		P
	<b>5.8 Catalogue number</b>		
	a) A medical device or accessory, or a combination of medical devices or accessories, may be identified with a catalogue number. b) Each unique catalogue number shall be related to a single, defined product specification. c) Multiple catalogue numbers may be associated with a single model number.		N/A
	<b>5.9 Production controls</b>		
	a) A production control associated with a medical device shall be identified by at least one of the following: <ol style="list-style-type: none"> <li>1) lot number;</li> <li>2) serial number;</li> <li>3) for medical devices containing cell tissues, donor identification information;</li> <li>4) year and month by which it is to safe to use; or</li> <li>5) year and month of manufacture.</li> </ol>	Serial number available.	P
	b) This information shall identify a controlled group of products associated with the production process for identification and traceability.		N/A



Clause	Requirement + Test	Result – Remark	Verdict
	<b>5.10 Unique device identifier</b>		
	a) Where necessary, a medical device or accessory shall be assigned a unique device identifier.	Basic UDI-DI: 4050063mwc folding7E in the DoC.	P
	b) This identifier shall have a 1:1 relation to: 1) a single catalogue number; 2) a single model number; or 3) a single commercial product name.		N/A
	<b>5.11 Types of use/reuse</b>		
	A unique use classification shall be assigned at the level of model number or catalogue number from one of the following: a) single use; b) single patient multiple use; and c) multiple patient multiple use.		N/A
	<b>5.12 Sterile</b>		
	a) A medical device or accessory that is sterile shall be identified as sterile. b) A sterile medical device or accessory shall be identified with the method of sterilization. c) Medical devices or accessories available sterile and non-sterile shall have different: 1) model numbers; or 2) catalogue numbers.		N/A
	<b>6 Requirements for accompanying information</b>		
	<b>6.1 Requirements for information to be supplied on the label</b>		
	<b>6.1.1 Minimum requirements for the label</b>		
	a) The information required in 6.1 shall be provided as a label.		P
	b) The information on the label shall be provided in a human-readable format.		P



Clause	Requirement + Test	Result – Remark	Verdict
	<p>c) The information required in 6.1 shall be provided as a marking unless:</p> <ol style="list-style-type: none"> <li>1) the size of the medical device or accessory does not allow fixation of this information on the medical device or accessory;</li> <li>2) the nature of the outer surfaces does not allow fixation of this information on the medical device or accessory; or</li> <li>3) the omission of these markings does not adversely affect the benefit/risk balance according to ISO 14971:2019.</li> </ol>		P
<b>6.1.2 Identification of the manufacturer</b>			
	<p>a) The label of a medical device or accessory shall include the name or trade name and, unless otherwise included in the IFU, the full address of</p> <ol style="list-style-type: none"> <li>1) the manufacturer; and</li> <li>2) where necessary, if the manufacturer does not have an address within the locale, an authorized representative within the locale, to which the responsible organization can refer.</li> </ol>	Manufacturer	P
	<p>b) In locales where the manufacturer or their authorized representative is required to be registered, the address used shall be the same as the registered address.</p>		P
	<p>c) Symbol ISO 7000-3082 or symbol 5.1.1 from ISO 15223-1, may be used to identify the manufacturer.</p> 		P
	<p>d) Symbol 5.1.2 from ISO 15223-1 may be used to identify the authorized representative.</p> 		N/A

Clause	Requirement + Test	Result – Remark	Verdict
	e) The medical device or accessory may be labelled with the country of manufacture using either: <ol style="list-style-type: none"> <li>1) a text string; or</li> <li>2) symbol IEC 60417-6049 or symbol 5.1.11 from ISO 15223-1.</li> </ol> 		N/A
<b>6.1.3 Identification of the medical device or accessory</b>			
	a) The label of a medical device or accessory shall include all of the following: <ol style="list-style-type: none"> <li>1) the details necessary for the user to identify the medical device or accessory and its use.</li> <li>2) a distinctive identification</li> </ol>		N/A
	b) The medical device or accessory shall be labelled with all of the following: <ol style="list-style-type: none"> <li>1) any special storage or handling conditions;</li> <li>2) any special operating instructions that need to be brought to the immediate attention of the user; and</li> <li>3) any necessary warnings or precautions that need to be brought to the immediate attention of the user.</li> </ol>		N/A

Clause	Requirement + Test	Result – Remark	Verdict
	<p>c) If the medical device or accessory, other than IVD medical devices, contains known allergens as well as phthalates or other substances, in a concentration that is above 0,1 % weight by weight, that are classified as endocrine disrupting, carcinogenic, mutagenic or toxic to reproduction shall be labelled as containing such substances.</p> <p>1) The symbol ISO 7000-2725 or symbol 5.4.5 from ISO 15223-1 may be used for latex.</p>  <p>2) The symbol EN 15986:2011 may be used for phthalates.</p>  <p>3) The symbol ISO 7000-3723 or symbol 5.4.10 from ISO 15223-1 may be used for endocrine disrupting, carcinogenic, mutagenic or toxic to reproduction substances.</p>  <p>4) The symbol ISO 7000-2725 may be used for other substances.</p> 		N/A
	<p>d) If applicable, the medical device or accessory shall be labelled with all the following:</p> <ol style="list-style-type: none"> <li>1) an indication that electronic instructions for use are available, if some or all of the instructions for use are e-documentation;</li> <li>2) if intended for single use,</li> <li>3) if intended for single patient multiple use,</li> <li>4) if reuse is limited, the limitation on reuse;</li> <li>5) as sterile and identify the method of sterilization;</li> <li>6) as containing biological origin substances; and</li> <li>7) as containing medicinal substances.</li> </ol>		N/A

Clause	Requirement + Test	Result – Remark	Verdict
	e) If containing nanotechnology materials, the medical device or accessory should be labelled with containing nanotechnology materials. 		N/A
	f) If the label includes symbols or safety-related colours, they shall be explained in the label.		N/A
<b>6.1.4 Other label requirements</b>			
	a) The label of a medical device or accessory shall include production controls, as applicable: <ol style="list-style-type: none"> <li>1) lot number;   </li> <li>2) serial number;   </li> <li>3) the year, month and day by which it is safe to use;   </li> <li>4) the year, month and day of manufacture, for a medical device or accessory without a date by which it is safe to use.   </li> </ol>	 and  available.	P
	b) The label of a medical device or accessory shall include a unique device identifier (UDI).	Not on the product because of the transition periode of MDR until 26.05.2025 of class I products.	N/A
	c) If the medical device or accessory is sterile, the label of a medical device or accessory shall include the year, month and day:		N/A
	d) The label of a medical device or accessory may include unique version identifier of the label.		N/A
	e) If the medical device, other than an IVD medical device, is for use by a single person and has been manufactured according to a written prescription or pattern (e.g., it is a personalized medical device), the label shall indicate that it is for use by a single person.		N/A

Clause	Requirement + Test	Result – Remark	Verdict
<b>6.1.5 Consult instructions for use</b>			
	a) When the manufacturer uses consulting the accompanying information as a primary risk control measure for a specific risk, (e.g., the instructions for use contain information for safety), the medical device or accessory shall be labelled with: 1) the mandatory action safety sign ISO 7010-M002; or  2) a text string to the effect that it is a mandatory action to read the instructions for use.		P
	b) Otherwise, symbol ISO 7000-1641 or symbol 5.4.3 from ISO 15223-1 may be used to advise the user to consult the instructions for use. 		P
<b>6.1.6 Safety signs</b>			
	a) For the purpose of this subclause, where a safety sign is used to convey a warning, prohibition or mandatory action that mitigates a risk that is not obvious to the user, it shall be a safety sign selected from ISO 7010.		N/A
	b) If a safety sign with an established meaning is appropriately used, the use of the general warning safety sign ISO 7010-W001 is not required.  NOTE In this context, warning is used to mean "There is certain danger"; prohibition is used to mean "You must not..."; and mandatory action is used to mean "You must...".		N/A

Clause	Requirement + Test	Result – Remark	Verdict
	<p>c) Where a safety sign is not available to indicate a particular desired meaning, the meaning may be obtained by one of the following methods.</p> <ol style="list-style-type: none"> <li>1) Constructing a safety sign according to ISO 3864-1:2011, Clause 7.</li> <li>2) Using the general warning safety sign ISO 7010-W001 placed together with a supplementary symbol or text.</li> <li>3) Using the general prohibition safety sign ISO 7010-P001 placed together with a supplementary symbol or text.</li> </ol>  <ol style="list-style-type: none"> <li>4) Using the general mandatory action safety sign ISO 7010-M001 placed together with a supplementary symbol or text.</li> </ol> 		N/A
	<p>d) If there is insufficient space to place the affirmative statement together with the safety sign on the medical device or accessory, the affirmative statement may be placed in the instructions for use.</p>		N/A
	<p>e) Additionally, a safety notice should include the appropriate precautions or include instructions on how to reduce the risk (e.g., “Do not use for ....”, “Keep away from .....”).</p>		N/A
	<p>f) Safety signs, including any supplementary symbol or text:</p> <ol style="list-style-type: none"> <li>1) shall be explained in the instructions for use; and</li> <li>2) if colour is not utilized in the instructions for use, the colour of the safety sign shall be described in the instructions for use.</li> </ol>		N/A
	<p>g) When supplementary text is placed together with safety signs, the supplementary text shall be in a language that is appropriate to the intended user.</p>		N/A

Clause	Requirement + Test	Result – Remark	Verdict
	<b>6.2 Identification requirements for detachable components of a medical device or accessory</b>		
	If misidentification can result in an unacceptable risk, detachable components of a medical device or accessory shall be labelled with all of the following:		N/A
	a) the name or trademark of the manufacturer;		N/A
	b) a distinctive identification; and <ol style="list-style-type: none"> <li>1) If a model number is used, it shall be identified by a text string; or symbol IEC 60417-6050. #</li> <li>2) If a catalogue number is used, it shall be identified by a text string; or symbol ISO 7000-2493 or symbol 5.1.6 from ISO 15223-1. REF</li> <li>3) If a commercial product name is used, it shall be expressed as a text string.</li> </ol>		N/A
	c) a production identifier in accordance with 6.1.4 a).		N/A
	<b>6.3 Legibility of the label</b>		
	a) The label and markings required in 6.1 shall be clearly legible when viewed from the intended position of the user performing the related function.		P
	b) The following test method may be used: If the intended position of the user is not specified and the position is not obvious, the viewpoint is at any point within the base of a cone subtended by an angle of 30° to the axis normal to the centre of the plane of the marking and at a distance of $(1 \pm 0,1)$ m or for medical devices intended to be held in the hand, at a distance $(0,4 \pm 0,1)$ m. The ambient illumination is the least favourable illumination level in the range of 100 lx to 1 500 lx.		

Clause	Requirement + Test	Result – Remark	Verdict
	<b>6.4 Durability of markings</b>		
	a) The markings on the medical device or accessory required in 6.1 shall be sufficiently durable to remain clearly legible, as applicable, during the medical device's or accessory's expected lifetime; or shelf-life.		P
	b) The markings required in 6.1 shall remain clearly legible under reasonably foreseeable environmental and mechanical impacts associated with the use of the medical device; and be removable only with an extra-corporeal object that can be used to secure or release a fastener; or by appreciable force.		P
	c) In considering the durability of the markings, the effect of normal use shall be taken into account.		
	d) The following test method may be used: Rub the markings on the medical device or accessory by hand, without undue pressure, first for 15 s with a cloth rag soaked with distilled water, then for 15 s with a cloth rag soaked with ethanol 96 % and then for 15 s with a cloth rag soaked with isopropyl alcohol.		P
<b>12.2</b>	<b>Pre-sale information</b>		
	Pre-sale information shall include the following:	Described in the IFU and is available at <a href="http://www.SunriseMedical.de">www.SunriseMedical.de</a>	
	a) information on how to obtain the user information in a format appropriate for use by visually impaired people;		P
	b) a description of the intended occupant of the wheelchair, including the occupant's mass;		P
	c) the intended operator (occupant, assistant or both), intended use and intended environment;		P

Clause	Requirement + Test	Result – Remark	Verdict
	d) the overall dimensions (width, length and height) of the wheelchair and its mass when it is ready for use and, if applicable, when it is folded and/or dismantled for storage or transportation;		P
	e) the pivot width;		P
	f) the maximum slope for use of parking brakes, expressed in degrees;		P
	g) the standard options that are available for the wheelchair;		P
	h) the type(s) of tyres (e.g. pneumatic, solid) that can be used on the wheelchair;		P
	i) if the wheelchair can be dismantled or has any removable parts, the mass of the heaviest part;		P
	j) a statement that the wheelchair is intended to be used as a seat in a motor vehicle, or a warning that the wheelchair is not intended to be used as a seat in a motor vehicle.		P
<b>12.3</b>	<b>User information</b>		
	User information shall be provided by the manufacturer with each wheelchair.	In paper form.	P
	Further copies shall also be available for any subsequent user of the wheelchair.		P
	User information shall contain the following where applicable:		
	a) the unique identification number of the wheelchair or information on the location of the unique identification number on the wheelchair;	A hint to find the serial number is available.	P
	b) any adjustment or settings required before the wheelchair can be used and warnings of how adjustments or settings affect stability;		P
	c) where applicable, information on any adjustments that can be made, and the competency required to carry out these adjustments;		N/A

Clause	Requirement + Test	Result – Remark	Verdict
	d) instructions on operation of all controls, including brakes;		P
	e) the wheelchair manufacturer's recommended tyre pressure(s), expressed in kPa, bar or PSI;		P
	f) instructions for dealing with tyre punctures;		P
	g) instructions on whether and how the wheelchair can be folded to assist in storage or transport;		P
	h) instructions on dismantling and re-assembly of the wheelchair or any removable parts;		P
	i) instructions regarding transport of the wheelchair when it is unoccupied (e.g. in a car or aeroplane);		P
	j) if the manufacturer specifies that the wheelchair is intended for use as a seat in a motor vehicle, the method of attaching wheelchair tiedown and occupant restraints, and recommendations about suitable tiedown and restraint systems;		P
	k) if the manufacturer specifies that the wheelchair is not intended for use in the motor vehicle, a warning to that effect;		N/A
	l) instructions on how to use the means for maintaining a sitting posture (see 8.4) and the circumstances in which it should be used;		N/A
	m) instructions on how to obtain and fit the means for maintaining a sitting posture (see 8.4) if it is not supplied with the wheelchair;		N/A
	n) the positions of points intended to carry additional loads; EXAMPLE Grocery basket, backpack hook.	No additional loads allowed by the manufacturer.	N/A
	o) information on the recycling of the wheelchair;		P

Clause	Requirement + Test	Result – Remark	Verdict
	p) if the characteristics of the wheelchair (including the occupant as applicable) exceed the limits specified in Appendix M of Commission Regulation (EU) No 1300/2014 [16], a statement to that effect (see Annex C for additional information);		N/A
	q) information on how to find out about product safety notices and product recalls, for example by ensuring the supplier has up-to-date contact details;		P
	r) the expected service life of the wheelchair;		P
	s) information on how to get repairs and servicing;		P
	t) warranty information.		P
<b>12.4</b>	<b>Service information</b>		
	The service information shall contain instructions necessary for the maintenance, adjustment and repair of the wheelchair and for the replacement of parts.		P
<b>12.5</b>	<b>Labelling</b>		
	The manufacturer shall apply permanent labelling for the following:		
	a) the maximum load of the wheelchair, i.e. the total of the maximum occupant mass and the maximum mass of any other items intended to be carried by the wheelchair;		P
	b) for wheelchairs where the intended use includes use as a seat in a motor vehicle, the position of attachment points for wheelchair tie-down and occupant restraint systems (WTORS);		P
	c) for wheelchairs not intended to be used as a seat in a motor vehicle, a warning to that effect.		N/A